

- 1) Tr. with Central Tap:
 D1 & D2 used. D3 & D4 not used
 Central tap connect to CT1
 Short connect CT2 - Anode D4 on PCB
 P : 220V S : 2 X18V
- 2) Tr. with NO central Tap:
 D1, D2, D3, D4 used.
 Tr. is to be connected to TR1 & TR2 on PCB
 P : 220V S : 18V

3 mA (R1=1K3)

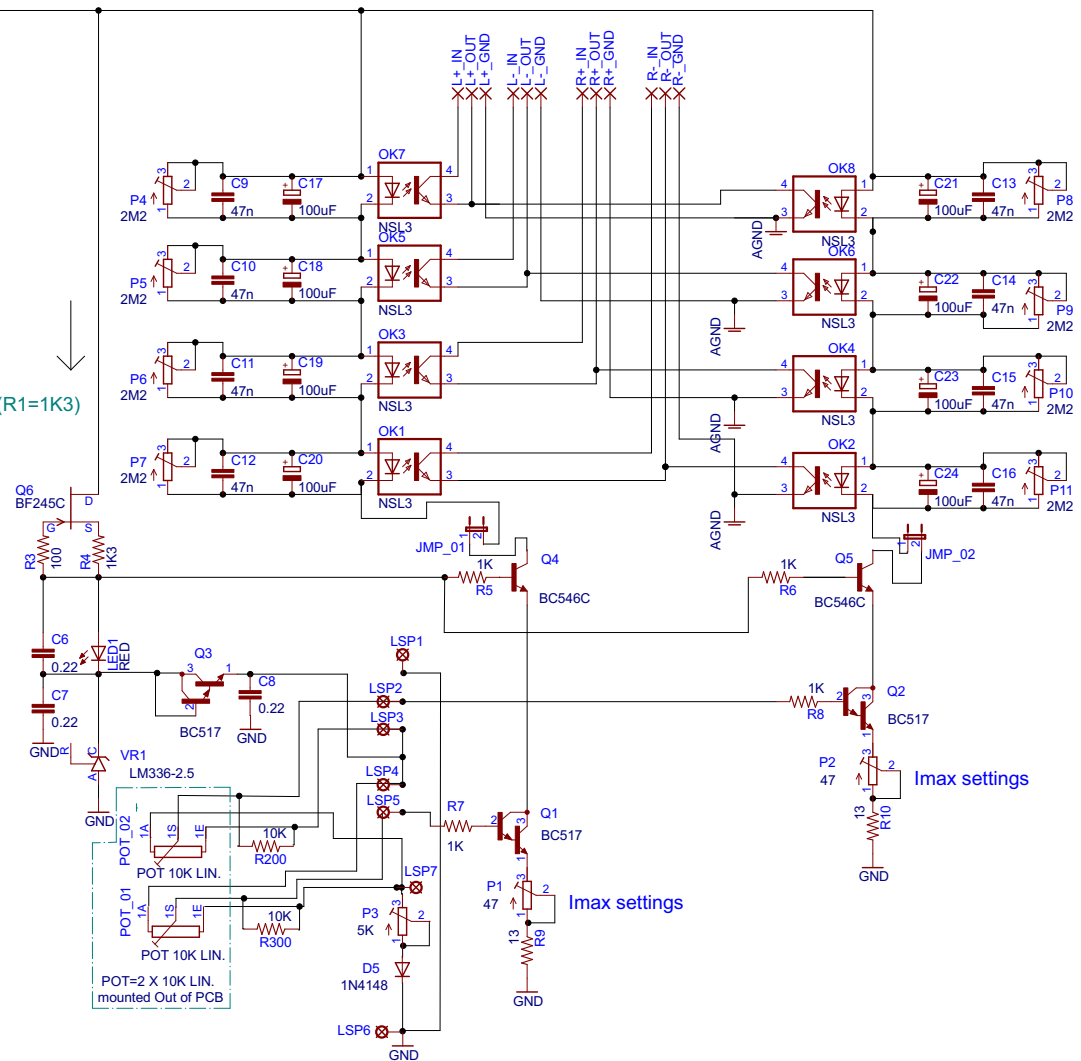

Rev D. New Labels for all elements aligned with PCB rev B.

PCB01 - DIY Poor Serbian LDR+Regulator

TITLE: PCB01_Electrical_Schematic_final_rev_D

Document Number: PSMLS

REV:

D

Date: not saved!

Sheet: 1/1