

POWER SUPPLY FILTER COMMON TO BOTH CHANNELS
 UNLABELED ELECTROLYTICS ARE 1,000+ uF
 OR GREATER @ 25V

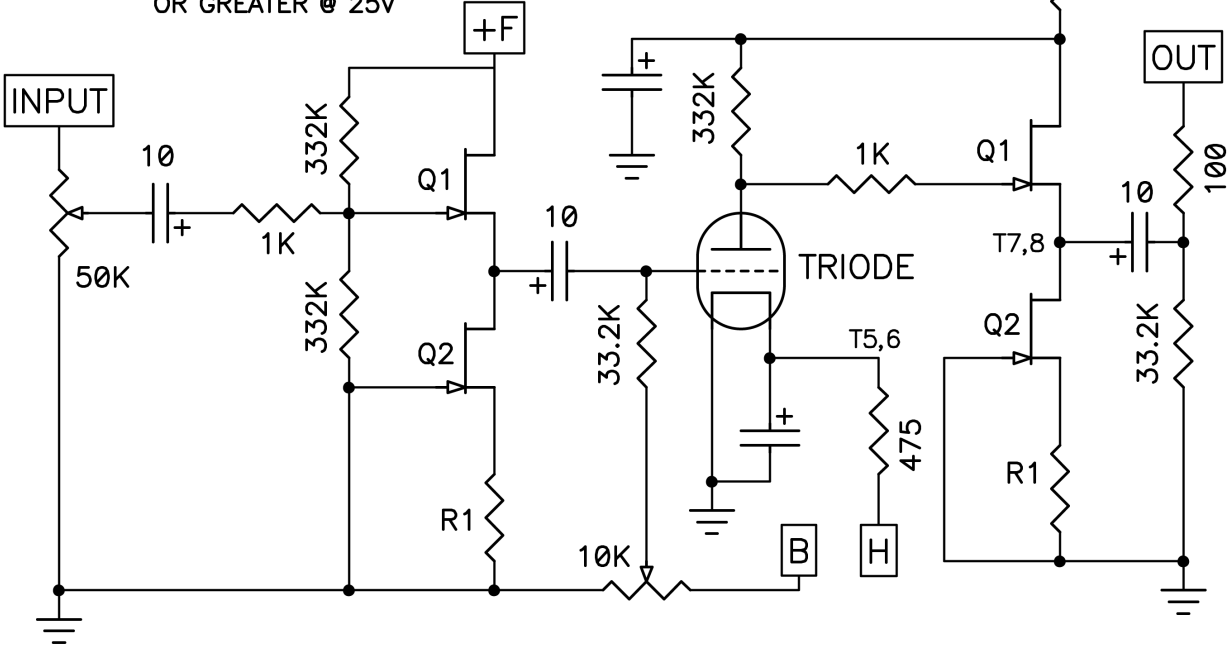

KORG NUTUBE DIY PREAMP
 V1 R0 (C) 2018 PASSWORKS

ONE CHANNEL SHOWN
 JFETS = MATCHED J113 OR
 2SK170 / LSK170 / 2SK370