

POWER PULSAR

ADM7150 CORE - THE 1.7 $\frac{nV}{\sqrt{Hz}}$ LDO

- Ideal for PULSAR CLOCK , superb for Analog Audio
- Capacitors Synergy Design, C0G + Tantalum + X7R
- Tunable Noise Loop, add your favourite Capacitor
- Any-board Install Accessories
- Three Pin Regulator Interface
- Input & Output status LEDs
- Small Size Board
- Input Bead Filtered with easy bypass feature

| | |
|-------------------------------------|--------|
| OUTPUT VOLTAGE | |
| Fixed | 3.3 V |
| INPUT VOLTAGE | |
| Minimum | 5 V |
| Maximum | 9 V |
| OUTPUT CURRENT | |
| Maximum | 800 mA |
| Limited only by thermal environment | |

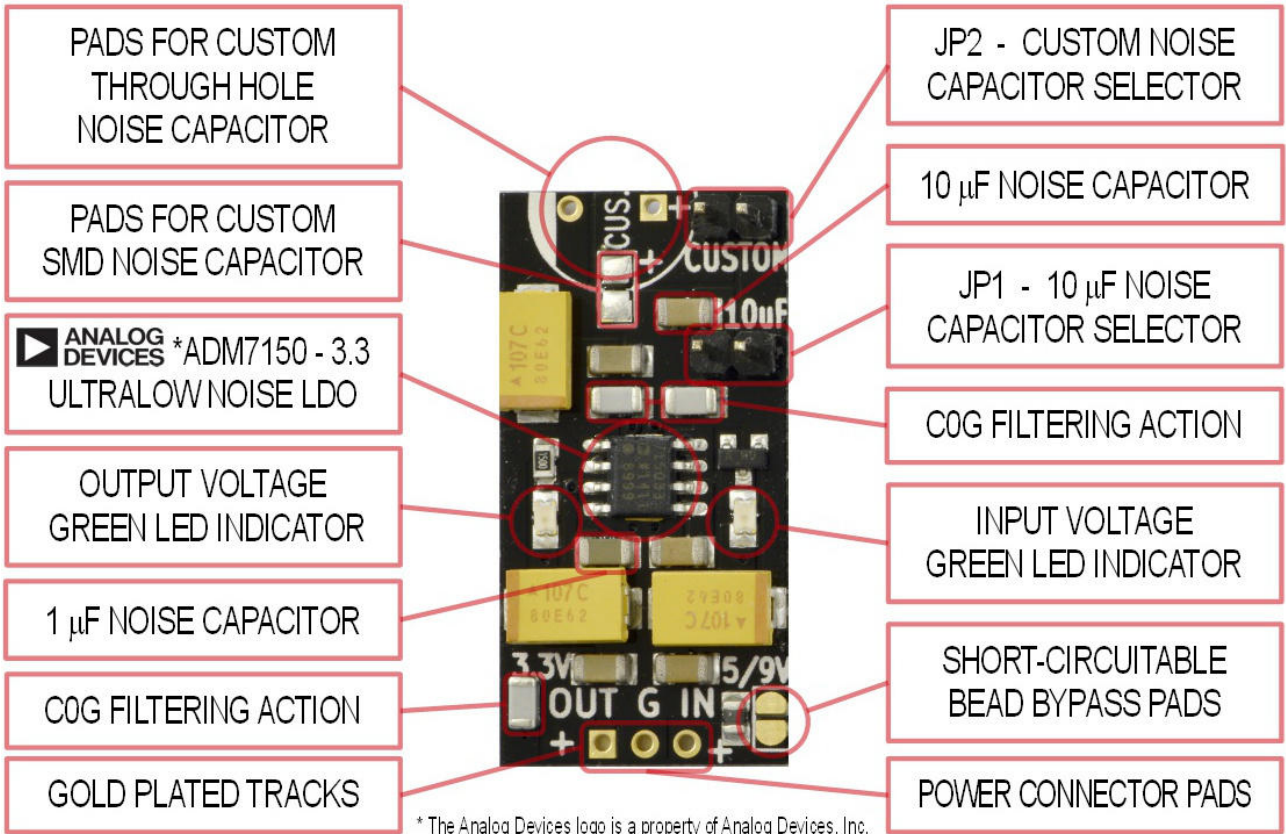

* The Analog Devices logo is a property of Analog Devices, Inc.



Overview

The Pulsar Power Board is a three-pin regulator that accepts an Input Voltage in the range +5 to +9 V and provides an ultralow-noise output regulated voltage of +3.3 V for low noise power supply demanding loads. The board is built around the Analog Devices ADM7150 Ultralow Noise, High PSRR, RF Linear Regulator. For a safe usage and information on accuracy and regulation performance you must refer to the ADM7150 datasheet freely available from Analog Devices website: www.analog.com

Digital & Analog Loads

Even if the Pulsar Power Board was originally designed to provide an optimum low noise power supply to the Pulsar Clock, the state of the art performance of the ADM7150 makes it the first choice power supply unit also for the noise-sensitive analog output sections of the most performing DACs.

Triple Technology

To get the best benefits from the ADM7150 regulator the whole Input to Output line is filtered with groups of paralleled capacitors exhibiting different technologies, they perform like musicians playing different instruments to cover all the voices that brings to life a perfect symphony. Each group is composed of a 100µF Tantalum, a 10µF XR7 and a 100nF C0G capacitor. One "trio" is placed on the Input, one on the intermediate V_{REG} and one on the Output pins of the ADM7150 so that the whole regulation path is properly and uniformly sustained during sudden current peaks requests by the Load.

Power Connectors

Three different 2.54 mm (0.1") connectors are provided in the package so you can fit your Pulsar Power Board in any design. Connectors are both pin socket and straight and angular pin strip models, the board is provided without any power connector installed so you can install the one of your need both on front or rear side or connect wires directly to the board. **Be aware that soldering any component is a potentially hazardous operation that must be performed only by a trained operator.**

JP1 & JP2 WARNING

Do not insert or remove jumpers JP1 or JP2 while the Pulsar Power Board is powered. Output voltage suddenly changes and this could damage both Your Load and/or the Pulsar Power Board.

CBYP Noise Capacitor

One of the peculiar features of the ADM7150 is the capability to trim the noise spectral density roll-off by means of the C_{BYP} Noise Capacitor. The influence of this control on the powered units is clearly audible and allows a perfect system tuning just changing the value of the C_{BYP} capacitor.

The Pulsar Power Board is designed to allow the user to tune very easily the system changing the C_{BYP} capacitor value just inserting or removing the provided jumpers on connectors JP1 and JP2 installing too your favorite capacitors. A 1µF C_{BYP} capacitor is permanently connected to the BYP pin. Inserting a jumper on JP1 a 10µF C_{BYP} capacitor is added to the BYP pin. Inserting a jumper on JP2 the C_{BYP} capacitors installed by the user on the "CUSTOM" pads are added to the BYP pin.

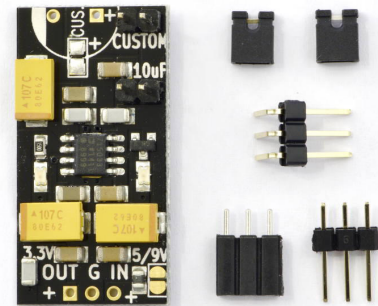
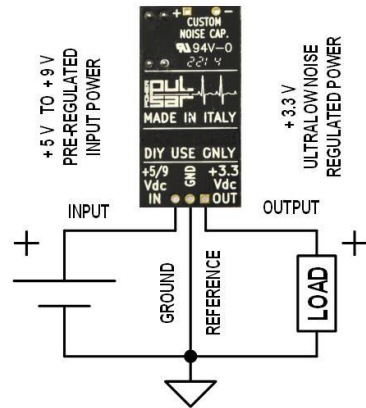

| JP1 | JP2 | Resulting C_{BYP} Noise Capacitor |
|-------|-------|-------------------------------------|
| Open | Open | 1µF |
| Short | Open | 11µF |
| Open | Short | 1µF + User Capacitors |
| Short | Short | 11µF + User Capacitors |

C_{BYP} Noise Capacitor WARNING

Output Voltage at power up increases very slowly if large custom C_{BYP} values are used. Experiment carefully with dummy loads before to connect your appliances to the Pulsar Power Board. Before to choose large C_{BYP} values consider that large C_{BYP} values unlikely are the best choice for optimal system performance despite the better noise roll-off.

Ferrite Bead

To improve the conducted EMI filtering capability a Ferrite Bead is placed on the input line. The bead operates only in the RF range of digital electronics giving benefits both to Digital and Analog Loads.

In case you desire anyway to bypass the bead, maybe just to test the effect, a convenient couple of short-circuitable bead bypass pads is available, just short them with a drop of stain without removing the bead. This makes very easy to reintegrate the bead just removing the drop of stain from the short-circuited pads with the tip of a soldering iron if you changed your mind.

Be aware that soldering printed circuit boards is a potentially hazardous operation that must be performed only by a trained operator.

Maximum Operating Current & Thermal Design

The ADM7150 is capable to operate with a current up to 800 mA, anyway, in order to operate in a safe condition and prevent the chip internal thermal protection from intervention generating trains of zero output voltage drops, the continuous load current must be limited as a function of the Input Voltage and the Ambient Temperature in the board location. Extreme care was taken to maximize the thermal dissipation of the chip through its thermal pad to the large ground plane on the rear side of the board, the design of the Pulsar Power Board guarantees proper operation of the Pulsar Clock both in warm-up and operating conditions. **The installer is responsible for the proper thermal design and integration in the operating location** taking into account the drop-off voltage, the operating current and the thermal constraints in the board location gathering the necessary information on the chip internal thermal protection and operation by the ADM7150 datasheet freely available from Analog Devices website: www.analog.com

ESD

Like any other electronic component the Pulsar Clock requires proper handling for ESD protection. Observe the necessary ESD protection procedures to prevent damage to the device due to electrostatic discharge. Be aware that ESD is responsible not only for components failure but also for less evident loss of performance of the electronic devices.

HOT SURFACE

The operating conditions could impose to the ADM7150 a significant thermal power dissipation and also in nominal operating conditions the chip could reach unsustainable temperatures for the human body; **do not touch the Pulsar Power Board during operation and few minutes after operation.**

POWER SUPPLY POLARITY and ORIENTATION

Both Input and Output Voltage polarity are Positive with respect to Ground Pin that is identified with the letter "G" near the Power Connector. **Do not apply reverse polarity to the device. Pay great attention to the proper Pulsar Power Board orientation**, an erroneous placement, rotating half a turn the board, have the consequence to exchange the Input and Output pins of the Pulsar Power Board. Applying reverse polarity to the Pulsar Power Board or exchanging the Input and Output pins unpredictable effects, even dangerous like fire or people injury could occur. The user is solely responsible for any consequence.

MISUSAGE

Pulsar Power Board has been uniquely designed to power the Pulsar Clock unit or Digital and Analog Audio DACs in home targeted DIY audio systems. Any other usage is not allowed and **the user is the only responsible for any consequence due to the usage of the Pulsar Power Board for any application different from those for which the board was designed.** The Pulsar Power Board integration design and installation must be performed only by expert personnel.

CONTACT

Address any question relevant the proper usage of the Pulsar Power Board to: pulsarclock@gmail.com

