

For a single ended input, short the "-" input to gnd



This symbol is a current source, shown in detail in drawing 2

Overall gain will be 20dB with the 'between the cathodes' trimmer set at 180R for single ended input – or 350R for differential input

| | |
|----------------------------|------------|
| PP-2C Triode Connection | Drw 1 of 2 |
| © 2004 by Allen Wright/VSE | Scale: |

VACUUM STATE ELECTRONICS

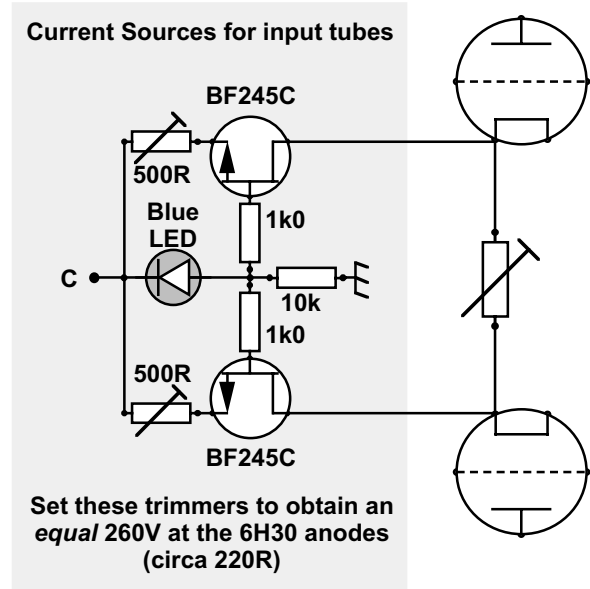
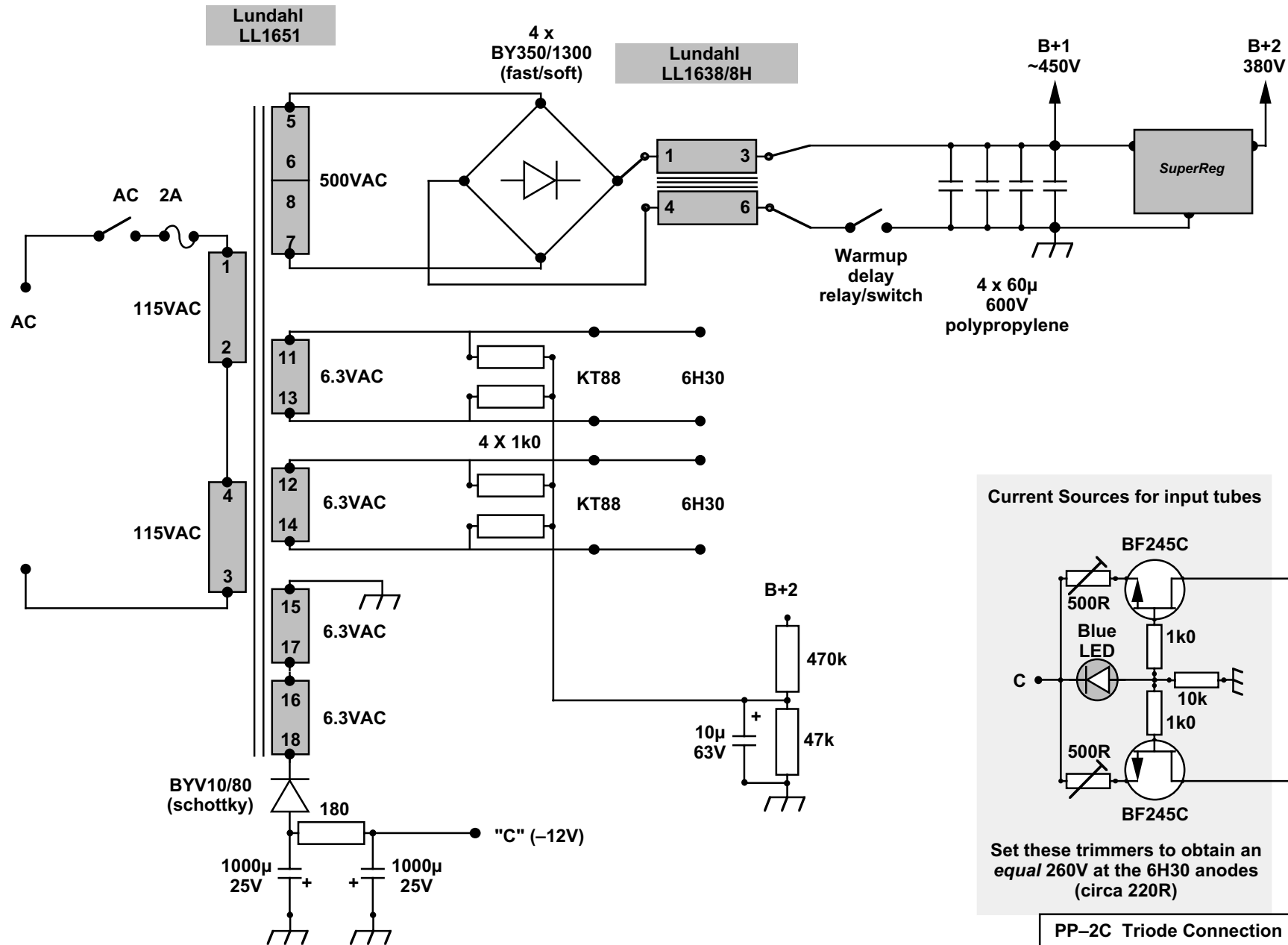

All resistors are 1 watt metal film 1% unless otherwise marked. Non-magnetic preferred. Except 100Ω which are 1/4 watt metal film 1%