

**FR810HQ
S05-189V1**

HEMP Acoustics

8" HEMP Acoustics FR8.0DIYHQ

- HempCone® With pre-treated accordian cloth edge
- Round Die Cast Aluminum Basket
- High Frequency Dual Cone
- 1", 8 ohm Kapton CCA Voice Coil
- 40 to 20,000 Hz Rated Frequency Range (tested in IEC 60268-5 Type A enclosure)
- 94 dB SPL Sensitivity at 1w/1m (3.3 ft)
- 1.5kg (3.30 lb) Net Weight

Price: \$105ea



Specifications and Small Signal Parameters

Voice Coil Impedance:	8	ohm
Rated Frequency Response:	40 - 20K	Hz
Sensitivity:	94	dB SPL (Average 500 - 2.5 kHz, 1w, 1 meter)
Rated Power:	45	watts
Program Power:	90	watts
Magnet Weight:	566	gr (20 oz)
Net Weight:	1.5	kg (3.30 lb)
Fo:	45	Hz
Re:	6.2	ohm
Qts:	0.41	
Qms:	2.5	
Qes:	0.5	
Vas:	88	liters
Mms:	12	grams
Xmax:	1.9	mm
No:	1.1	%

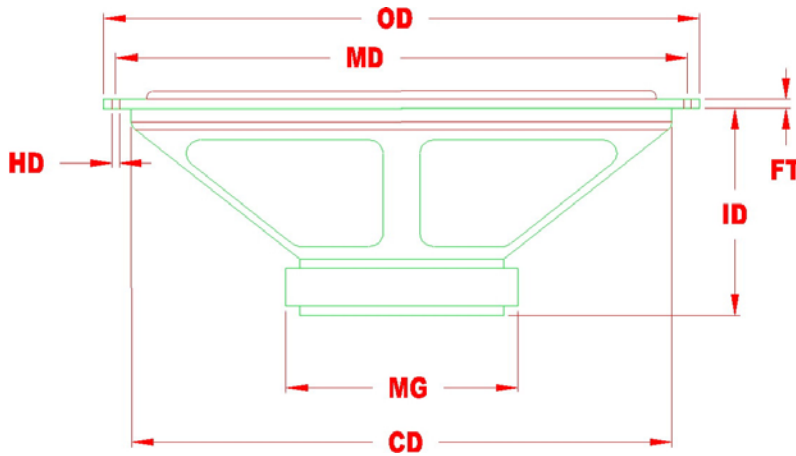
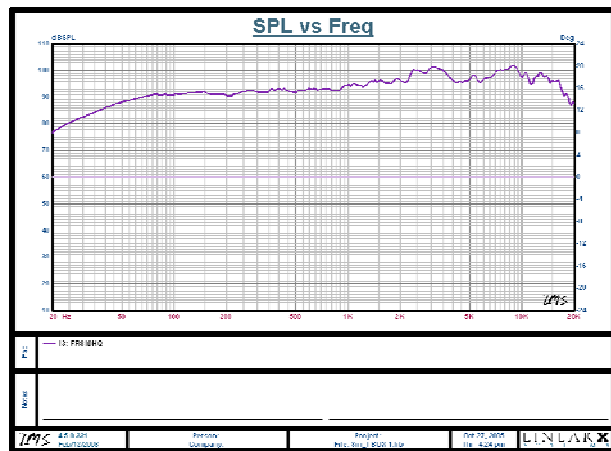

ID	Description	Measurements	Units	Comments
OD	Outside Diameter	8.81	Inches	
CD	Cutout Diameter	7.25	Inches	
MG	Magnet Diameter	3.37	Inches	
HD	Hole Diameter	.23	Inches	+/-0.010"
MD	Mounting Diameter	8.25	Inches	+/-0.010"
ID	Internal depth	3.75	Inches	+/- 0.125"
FT	Flange Thickness	.24	Inches	+/-0.050"

HEMP Acoustics.

Specifications subject to change without notice

www.hempacoustics.com. 818-456-6490

Designed & Made in U.S.A.