

bass-ic instinct

PART 4 - Floorstander

Designer Peter Comeau describes the floorstanding version of World Design's WD25A loudspeaker, the WD25T.

For those who haven't read the first THREE articles, the WD25A kit loudspeaker is based on an aperiodic cabinet design that first achieved popularity in the Dynaco A25.

Why aperiodic? This type of cabinet loading offers the good bass clarity of a closed box (so-called infinite baffle) system, but with A much lower resonant peak, in other words it gives you bass without the boom.

The first three parts described a stand mounter. Here is a floorstanding version.

Whenever we have demonstrated the WD25A there have been more than a few of you who have asked 'Are you doing a floorstander?' Here, then, is the solution you have been waiting for – the WD25T.

There are further opportunities with the floorstanding version to achieve an extended bass response whilst keeping the bass unit fully under the amplifier's control. If you look at the cross sectional diagram of the cabinet you'll see that the upper part is roughly the same volume as the WD25A. The aperiodic vent has now moved to a shelf about half way

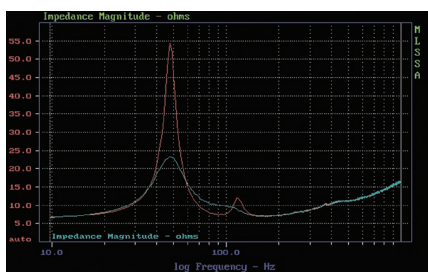

Fig 1. Impedance peak (red) is reduced by aperiodic foam loading (blue).

down the cabinet and 'ports' into a lower chamber.

At first sight this seems an odd thing to do – surely the cabinet should 'port' into open air? The point here is that we are doing something entirely different to the stand mount design. In the WD25T the whole of the cabinet is loading the driver and this would normally result in a fundamental resonance, and peak in the impedance, as shown by the red line in Fig 1. By dividing up the cabinet into two chambers and adding the aperiodic vent we can control this resonance as shown by the reduced impedance peak graphed as the blue line.

What appears to happen is that the bass unit 'sees' only the upper

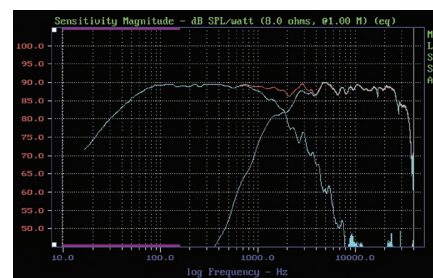
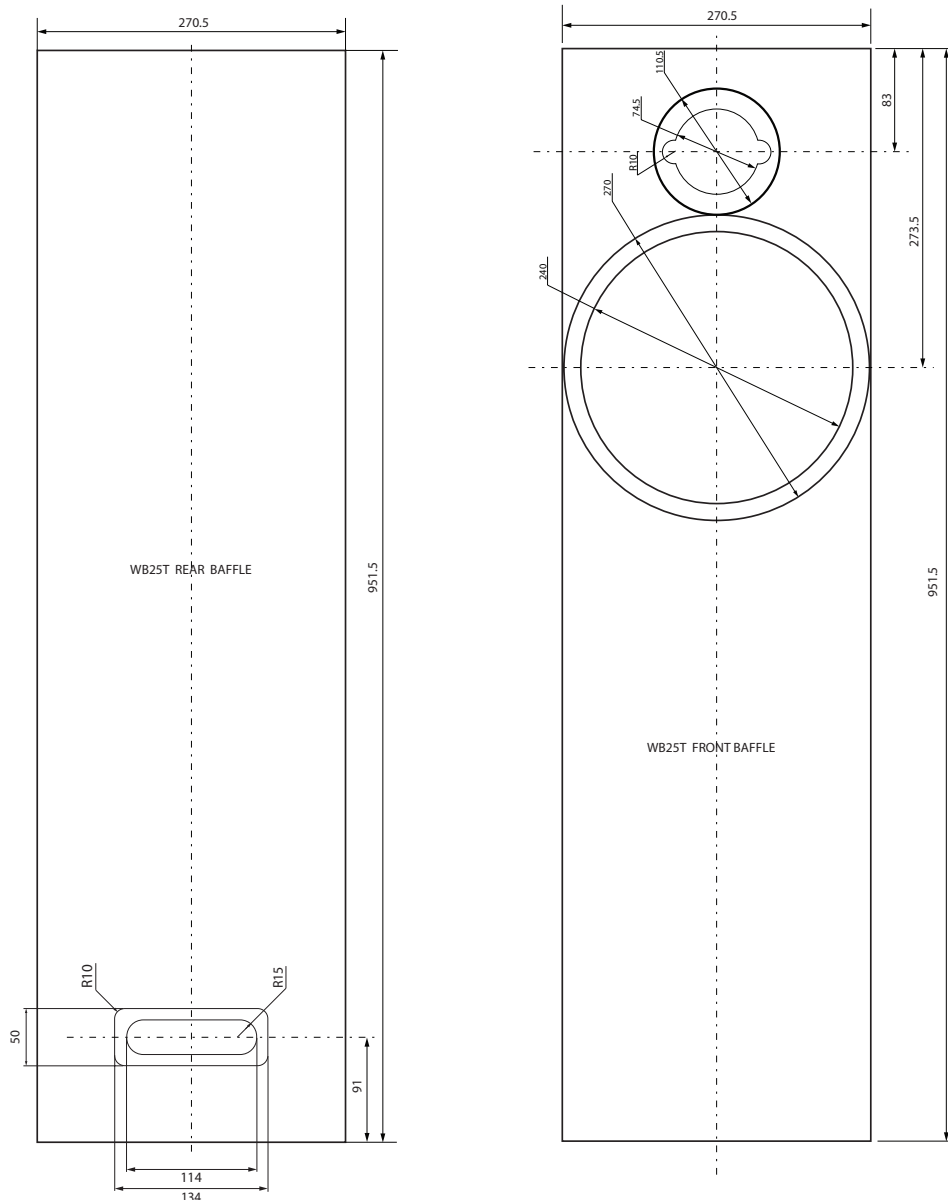

Fig 2. Better integration between the drivers with the new crossover giving a smoother response.

chamber throughout the upper bass and midrange, resulting in the clean, tightly controlled and detailed performance one expects from smaller cabinets that are free from low frequency standing wave modes.



Front and rear baffle dimensions

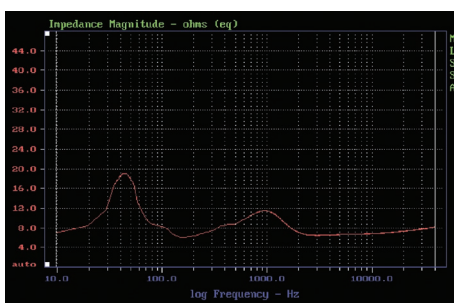

Fig 3 - The impedance curve of WD25T is relatively smooth; it is an easy load.

As the driving frequency reaches the fundamental resonance the bass unit starts to work with the whole cabinet volume but is resistively damped by the increasing air velocity through the reticulated foam in the aperiodic vent. This helps keep the bass under the control of the amplifier and smooths the 'knee' in the low frequency response as the bass output starts to fall away.

Below resonance the air velocity

through the aperiodic vent is low so that the bass unit 'sees' the whole cabinet volume and behaves like a critically damped closed box system with a classic roll off of 12dB per octave. The key to keeping the bass tightly controlled and free of resonant booming is to let the aperiodic vent decide the damping and use just enough fibre filling in each chamber to absorb internal reflections.

One added bonus is that the aperiodic vented shelf half way down the cabinet also minimises the full column standing wave mode that you normally see in a floorstanding speaker in the 150 – 200Hz area.

Of course we could achieve a similar result by using a well damped closed box, but the point is that, in order to lower the Q at resonance and reduce the impedance to the same level, we would have to use a greatly increased box volume

with a fibre fill of around 70%. The aperiodic vent between the chambers gives us the same low Q but in a much smaller cabinet.

The result is a speaker which plays bass notes evenly all the way

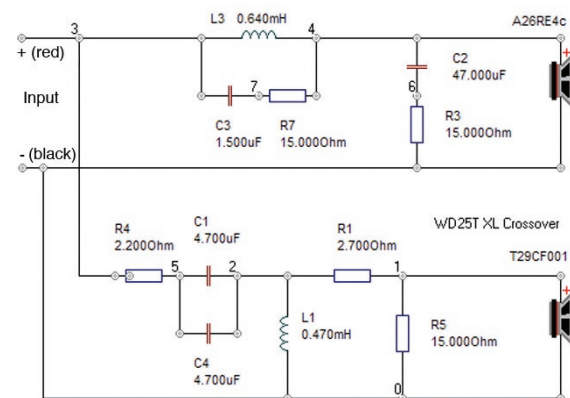
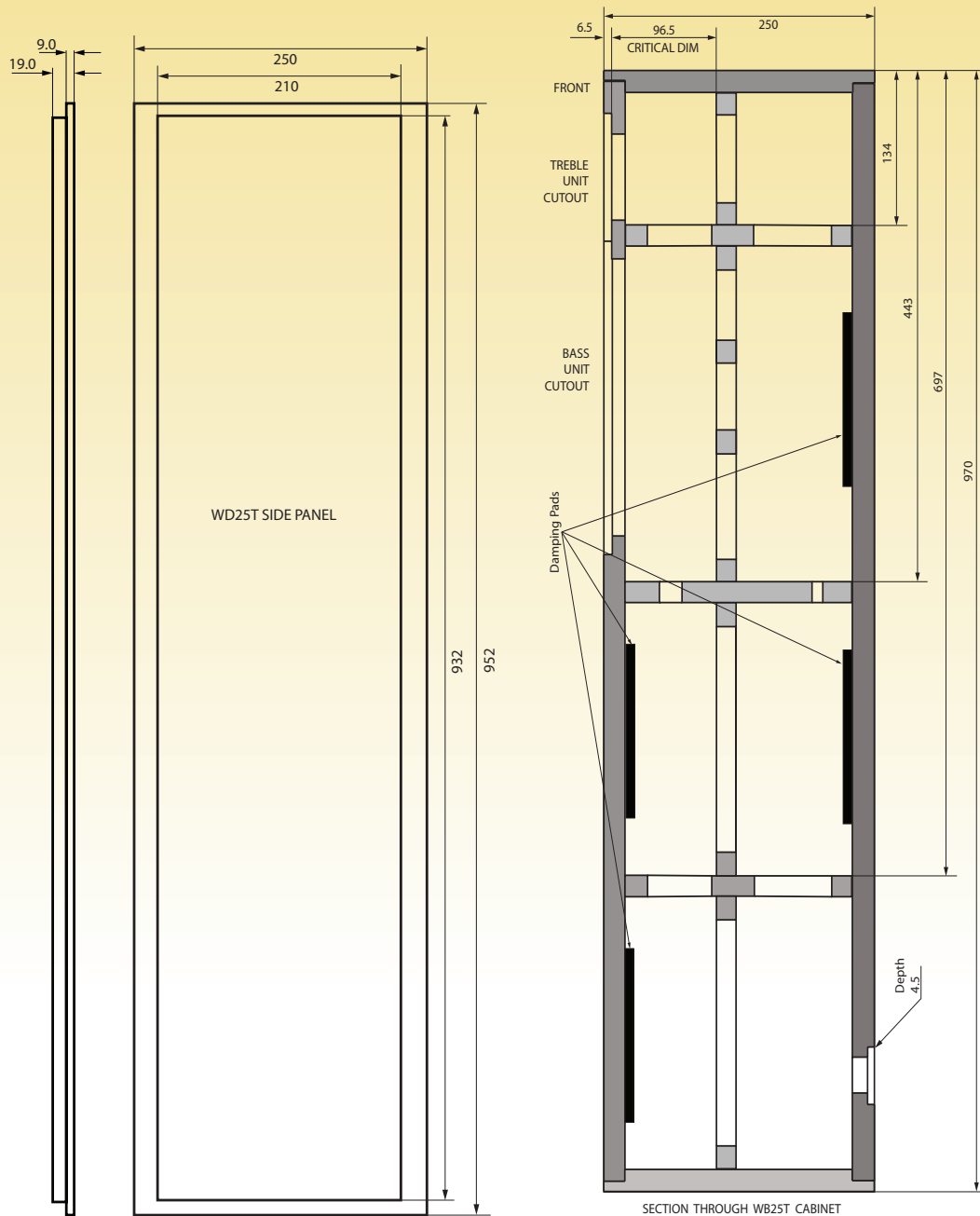

Fig 4. Crossover diagram of the WD25T; a neat solution to driver integration.



Side panel dimensions.

A cross section through the cabinet showing positioning of braces and baffles.

down to the lowest fundamental of bass guitar and reproduces drums with excellent transient impact and no overhang. It also integrates with room acoustics well and is ideal stood close to a rear wall where you can expect good bass extension down to 32Hz. Obviously the power developed down here is not as great as you would achieve from a Transmission Line enclosure, but then the cabinet size is far more manageable!

Another benefit of the floorstanding cabinet over the stand mount is the larger baffle area 'seen' by the bass unit. This significantly smooths the cabinet diffraction effect giving a more even midrange response. So much so that we made small changes to the crossover to

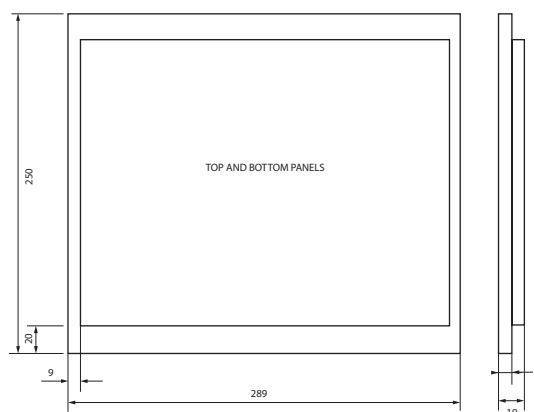

Top and bottom panel dimensions.

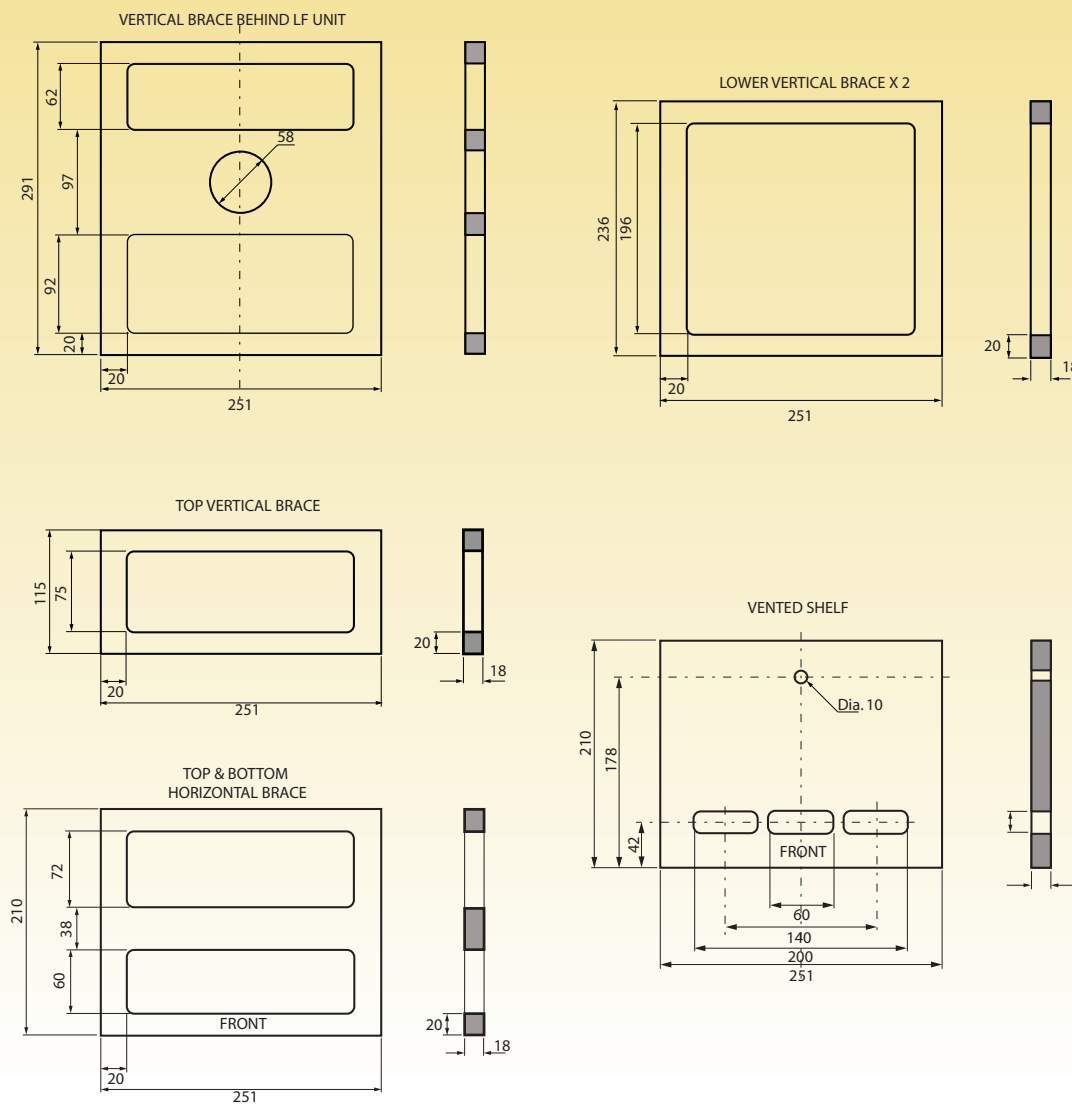

Internal baffle and brace dimensions.

accommodate the fuller midrange output.

Fig 2. shows the overall performance of the system 'in-room' and the crossover slopes. With the benefit of a bit more work, both in LspCAD and in the listening room, we were able to refine the slope of the bass unit so it adheres more tightly to a Linkwitz 3rd order acoustic filter response. This is the result of the added filter elements across the bass coil which allow the removal of the coil in the impedance compensation across the bass unit. The treble crossover has been adjusted to match and the phase response through the crossover region is now excellent. Altogether I feel that this is a much neater result conceptually and certainly improves the midrange coherence, giving the added bonus of more precise stereo imaging, and is musically very lively and engaging.

As for cabinet construction, we've kept to veneered MDF as the cut edges are so much easier to edge band with self-adhesive veneer

strip. In response to other questions yes, of course you can use birch ply, Baltic ply or high density chipboard if you've a mind to. Notice from the cross sectional diagram that we have added damping pads to control the cabinet panel resonance that tends to add coloration in larger cabinets. We have used 6mm thick butyl rubber sheet but you can also use bitumastic pads built up to the same thickness, or anything else you prefer. Overall pad size is 150mm x 165mm and you will need four per cabinet.

Fibre filling consists of one piece of fibre positioned as a 'U' behind the bass unit, plus some bits lining the sides of the cabinet, and two 'U' shaped pieces in the bottom chamber. Each piece of fibre is 250mm x 660mm. As before, we used reticulated foam, (a 215mm x 38mm x 12mm strip of 80 ppi reticulated foam) for the aperiodic vent, stuck down firmly all round to avoid 'flapping'.

Due to the bottom chamber being sealed you will need to insert the crossover and cables through

the terminal panel hole before fitting the front baffle and feed the cables through the 10mm dia hole in the shelf below the bass unit, making sure this hole is sealed tightly with mastic.

All joints have to be fully airtight, so don't skimp on the glue when building. A fully oak-veneered cabinet kit, with pictorial instructions, is available from World Designs if you don't fancy cutting the woodwork (and judging by our correspondence many don't)! Full details of all the components required are available on the World Designs website, www.world-designs.co.uk.

Next month: Tuning WD25 - how to get the sound you have always wanted.

Coming soon: A KT88 push-pull valve amp. using the latest and best transformer design from the masterkind, Andy Grove. Don't even think of missing this if you are interested in a top quality 40W valve amplifier!