

Crown's Grounded Bridge Output Topology

The term grounded bridge refers to a power amplifier output stage topology. It is a unique design patented and used by Crown in a variety of professional audio amplifiers.

AMPLIFIERS 101

In any power amplifier the input voltage is sensed, then it is increased. This process is called voltage amplification. Once the voltage is sufficient then the current must be amplified. This is necessary because audio loads have a low impedance (typically 2 to 8 ohms). Since current is a function of voltage, given a fixed load, the amplifier needs to increase its output current to meet the demand of the load for the amplified voltage.

A transistor is a solid state device used to amplify voltage, current, or both. Transistors come in two distinct types, NPN and PNP. The only difference is which direction current (electron flow) goes through the device, and the polarities of applied voltage to cause that current flow. Refer to Figure 1. In either case current through the base-emitter leads controls a proportionally larger emitter-collector current. The details of how the device works internally is of little importance to understanding the larger picture.

Configurations

There are three major transistor amplifier circuit configurations. These are called common base, common emitter, and common collector (a.k.a. emitter-follower). See Figures 2-4. Common base configurations allow for high voltage gain without current gain. This is not suitable for an output stage. Common emitter circuits allow moderate voltage and current gain. Common emitter circuits are not used in output stages, however, due to limited current handling capability. Also voltage amplification is

accomplished in preceding stages so it is not needed. Both the common base and common emitter circuits are used in Crown amplifiers, however not in the output stage.

The emitter-follower circuit (common collector) offers high current gain without voltage gain, thus it is the ideal configuration for the output stage of an amplifier. Crown actually combines emitter-follower circuits into stages for a higher total current gain with lower distortion.

Bias

Bias is a technical term referring to the static operating condition of a transistor. In other words, bias defines how much conduction takes place with no dynamic signal input.

Classifications

The amount of bias determines the classification of a transistor amplifier circuit. There are three primary classes:

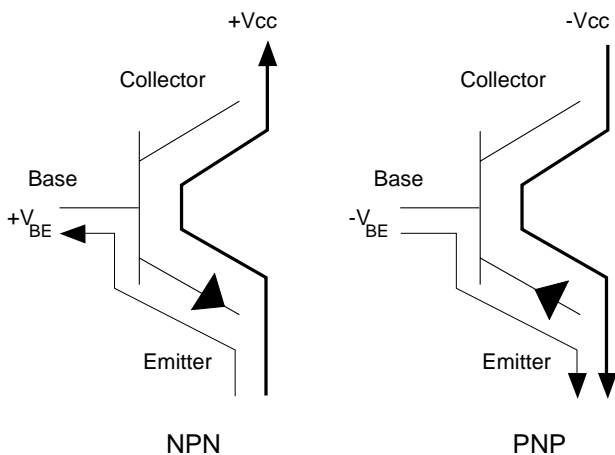

Figure 1. Transistors Types

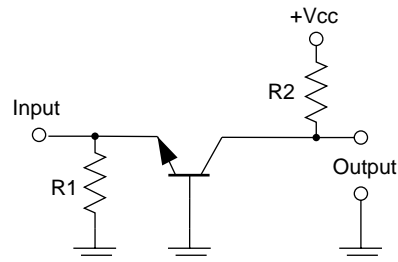

Figure 2. Common Base—Voltage Gain

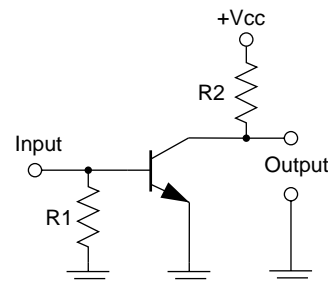

Figure 3. Common Emitter—Voltage and Current Gain

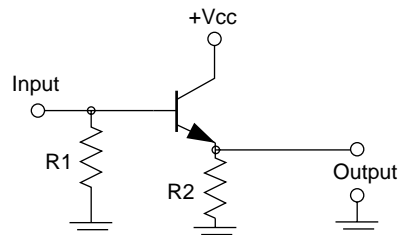

Figure 4. Emitter-Follower—Current Gain

A, B, and C, and combinations thereof. Figure 5 shows a comparison of the classifications.

Class A amplifiers conduct all of the time. The advantage is no danger of any distortion in the zero-crossing region of the audio. Disadvantages are very low efficiencies and tremendous amounts of heat. Heat, in turn, has a great effect on physical construction. Only a handful of high-end esoteric manufacturers use this technology in their output topologies.

Class B amplifiers are as much as 50% efficient. This is an improvement, but due to the fact that the transistors are biased completely off with no signal applied this circuit type produces high distortion in the zero-crossing region. A purely class B design is not acceptable for audio.

Class C amplifiers conduct for less than 180° and rely on an output LC network to produce the balance of the signal. Such a design is sometimes found in RF amplifiers, like radar, due to its extremely high efficiency. It is not possible, however, to use such a design with audio.

Class AB is a combination of classes A and B. A pure class AB amplifier circuit is actually capable of up to 78% (theoretical) efficiency with no distortion in the zero crossing region. This is accomplished by using a push-pull class B circuit, but with bias circuitry modified to keep the devices slightly on with no audio.

AB+B Combined Classification

Crown capitalized on the AB design and modified it further. The term “Darlington” refers to ganged emitter-follower stages for higher current gain. Refer to Figure 6. Crown found that by using a three-deep Darlington, the individual devices could be biased separately. The first device in the chain is called the predriver, and second is the driver. Together these two devices are biased operated class AB. In other words, they are biased a little bit on, even without signal. Since they are small devices

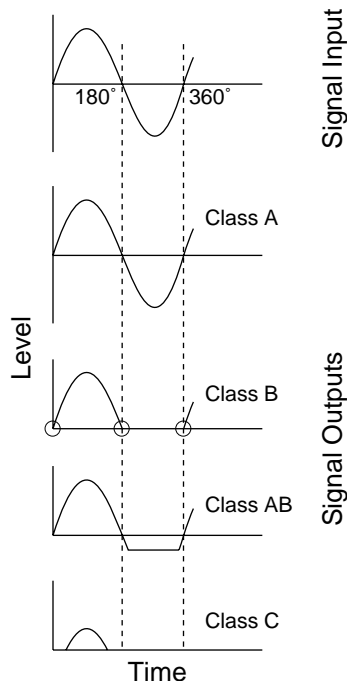

Figure 5. Classifications

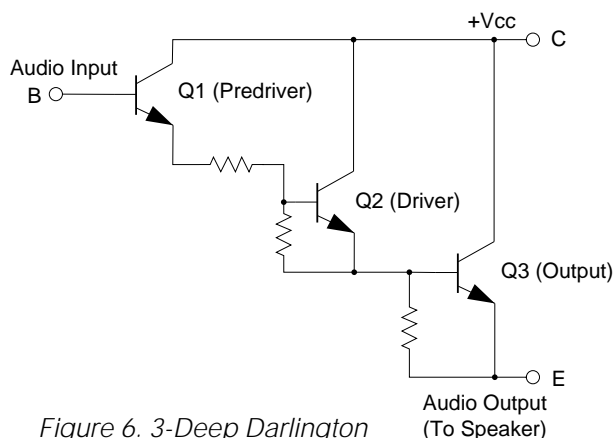

Figure 6. 3-Deep Darlington AB+B (Positive Half Shown)

(compared to the third part of the Darlington) they do not generate a lot of heat, but provide a smooth output to the load even through the zero-crossing region. The last part of the Darlington is the output transistor device. The output device is biased so that it is off when no signal is applied, but requires only a small signal to begin conduction. Combining the AB stages with a class B stage produces a net classification of AB+B. The clean output of an AB class is obtained with the high thermal efficiency of the class B. This technology was originally developed by Crown and implemented in the DC-300® (1966). Today nearly all audio amplifiers use this general configuration.

As you probably know, placing two batteries in parallel allows for double the current capacity; while placing two batteries in series doubles the voltage. Transistors may also be placed in series or parallel. Consider first the parallel option. A horse can only go so fast. Two horses, side by side, still can only go so fast, but together they can pull a heavier wagon. Roughly translated, parallel transistors share the load.

A simple AB+B output configuration will usually have one predriver, one driver, and multiple output devices in parallel. To obtain a full 360° of conduction a mirror image of components form the negative half. This creates the push-pull effect and completes the design.

Thermal Considerations

Power dissipated by a transistor, like power dissipated by a resistor, is dissipated in the form of heat. Heat is a function of the amount of current and the opposition to that current, or impedance. Stated in the form of math, power dissipated as heat is a function of I²R. Transistors act a lot like variable resistors. When no signal is present there is little or no current through the device, so it dissipates very little power (heat). At maximum conduction the device drops very little voltage, so its impedance

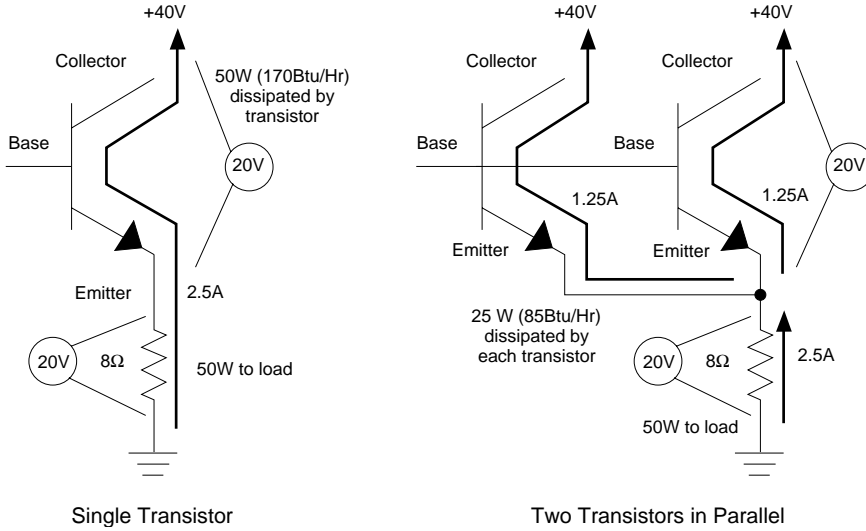

Figure 7. Single Vs. Parallel Output Transistors

is very low. Although current is high, the device does not generate a great deal of heat due to the low impedance. The worst possible thermal condition takes place, however, at about 1/3 of full power. By placing transistors in parallel, they will share the current load, hence they also share the heat dissipation.

using a conventional design. It does, however, have several disadvantages.

Power Supply

Getting back to basics, let us look at the concept of two batteries in series. When two batteries are in series, total

Summary of Fundamentals

The AB+B configuration developed by Crown has become an industry standard and is used by most amplifier manufacturers, even if they do not use the name AB+B. It is a highly efficient design offering low distortion. To handle higher current drive, final output transistors are often arranged in parallel.

Today's technology limits the voltage that can be applied to a transistor on a long term basis. Also, as the applied voltage increases, so does the power that transistors dissipate as heat. The only way to get more power to a load is to operate with higher available power supply voltages. There is more than one way to increase available source voltage, thus increasing maximum output power. The grounded bridge topology is one way of accomplishing that goal. To better understand why

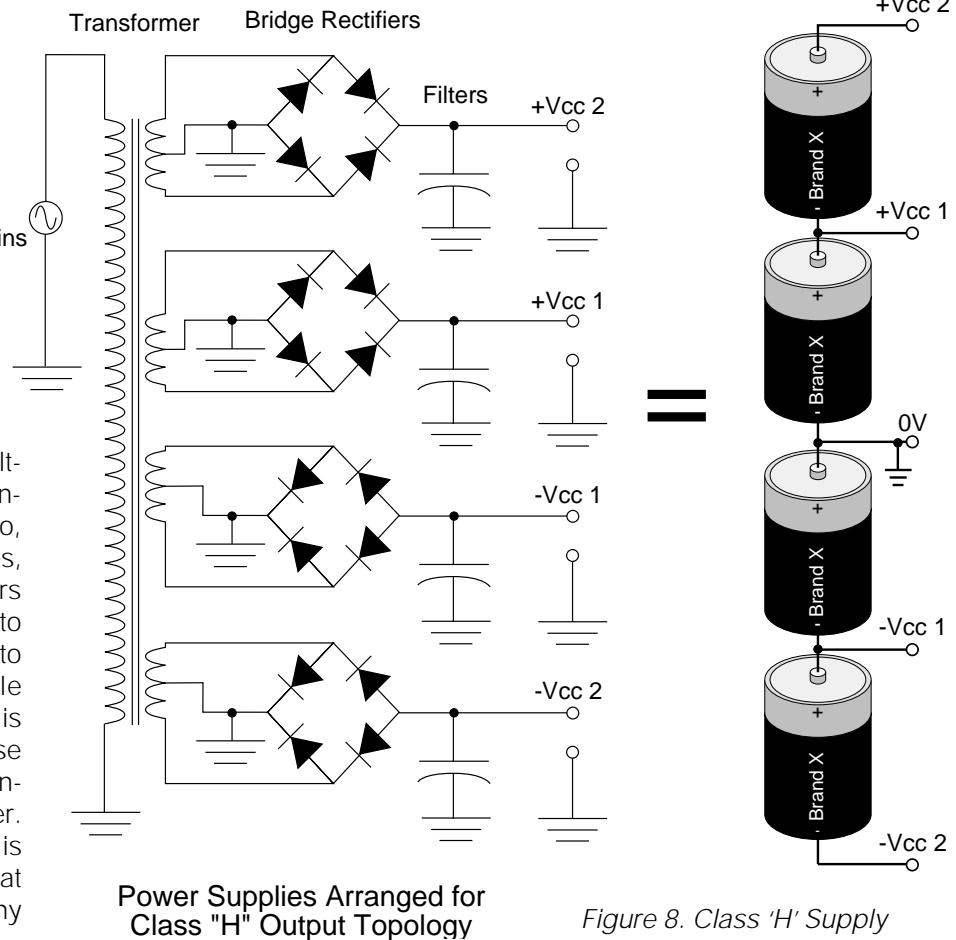

Figure 8. Class 'H' Supply

voltage ($V_{cc 2}$) equals the sum of the two supplies. With respect to ground, voltage measured at the top of first battery is only the voltage of the one supply ($V_{cc 1}$). The output stage delivers power to the load, but it cannot function unless a power supply provides the energy to the output stage. Figure 8 shows a simplified class "H" power supply and the series battery concept.

A conventional power supply design will usually use a center tapped secondary power transformer. One side will supply a bridge rectifier and filter network for the positive supply, and the other side a bridge rectifier and filter for the negative supply. Disadvantages are that two rectifiers and two filters are needed (one positive and one negative). Each is utilized for only half of the audio signal. This is a common type of power supply for small amplifiers. A supply of this type can be constructed which can supply very high voltages safely. Unfortunately, as stated before, transistor technology limits supply voltage.

To get around this in class "H" amplifiers, the output transistors are placed in series and multiple supplies are used. Four supplies required. The cost is high because of the number of components required. These parts also take up a lot of space inside a chassis.

Before attempting to explain difficulties associated with the output stage, take a look at the problems just with the transformer technology. For a transformer to operate efficiently, primary and secondary windings must be as physically close as possible. This is a problem when there are four secondaries on a core common to one primary. No supply will be used more than 1/2 of any audio cycle. Some manufacturers' supplies will be more efficient than others, but still a great deal of energy and resources are wasted.

Output Topology

Now that the supply has been discussed, let us look at how the output stage works and why the output stage of a class "H" amplifier is less than desirable. Figure 9 shows a graphic comparison of a single transistor with

an 80V supply to the class "H" arrangement with two power supplies and two transistors in series. In actuality neither is really very good, even with an equal number of parallel transistor branches (not shown). The lone transistor has the problem of attempting to care for all of the output. 80V can generate a lot of heat, and the transistor has an output far removed from the worst case 1/3 power condition. Besides this, 80V is very high for any transistor, and for even higher power a single device would be in a great deal of

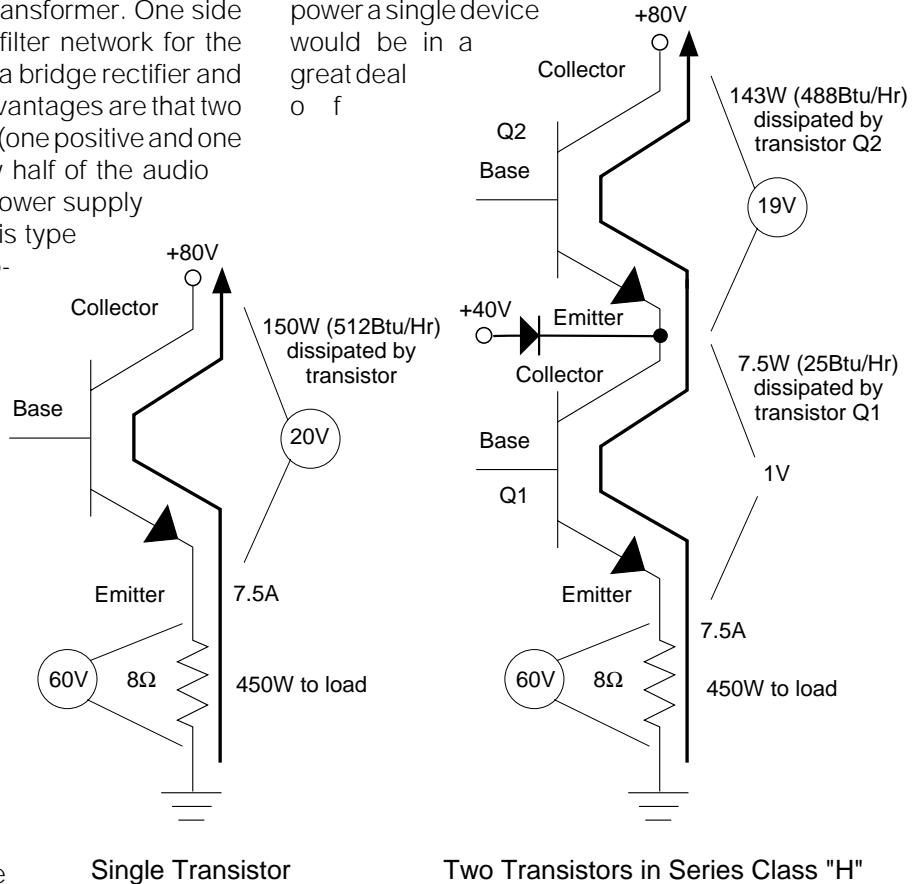
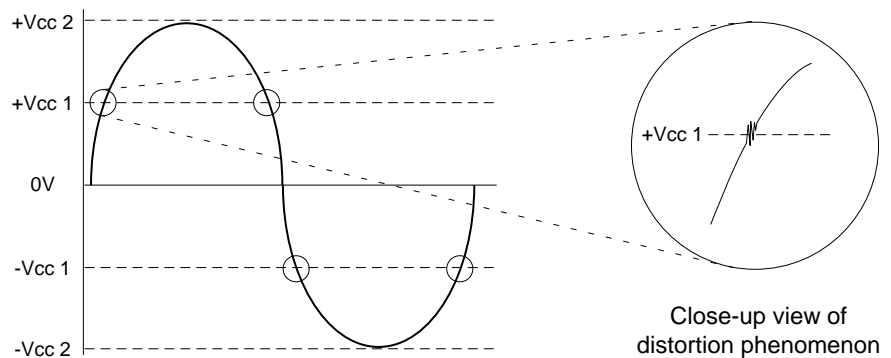

Figure 9. One Transistor Vs. Two Series Transistors



Class "H" Output Waveform. Circles around points where transistors enter and leave saturation.

Figure 10. Distortion Found In Class 'H' Amplifier Output Signal

trouble. To the right is the class “H” arrangement. On one hand neither transistor has to dissipate all of the heat, so neither is taxed as hard as a single device would be. On the other hand the two devices do not share the burden equally. Up to +40V the first transistor (Q1) does all the work. Above this point the second transistor (Q2) begins to conduct.

Aside from the inequality, a far more powerful reason exists for avoiding this design. When a transistor is turned on fully and is conducting at its maximum level, it is said to be saturated. In the left side of Figure 9 the transistor is not saturated, although it does dissipate a lot of heat and is much closer to its voltage limits. To the right there are two transistors in series. Before the second transistor can turn on, the first transistor must reach maximum conduction and go into saturation. Saturation is bad because transistors near, entering, or leaving saturation act non-linearly. In other words, distortion occurs as the audio level goes above and below the saturation point of Q1, the lower transistor. In the example shown this is at about 1/2 of maximum output voltage, or 1/4 output power (power is a function of V^2). Refer to Figure 10.

The amount of distortion is fixed. Raising and lowering audio level will affect the signal to noise ratio any time the output exceeds 1/4 power. Because signal to noise is actually measured by finding the noise floor with no signal then comparing it to rated output, *the additional noise is not accounted for in class “H” specifications!*

THE GROUNDED BRIDGE

Fortunately there is more than one way to get higher power levels safely. The grounded bridge topology solves the problems of the overgrown and inefficient power supply, unequal thermal characteristics of the series topology, and the distortion peculiarities associated with splicing the output signal across power supplies.

Ground Bridge Power Supply

The grounded bridge output topology cannot be effectively understood without understanding the power supply. To understand why the power supply is unique, let’s back up further to another fundamental: the term “ground.” Ground is a common reference, generally considered to be at 0V. Most other voltages are measured using this 0V reference. In fact, this philosophy is embedded so deep in the psyche of audio engineers, that they have difficulty thinking about a power supply not referenced to ground.

In our examples thus far, all of our batteries and supplies have been shown with a reference to a common ground (0V) point. A real battery, however, has two posts (positive and negative with respect to each other). Neither of

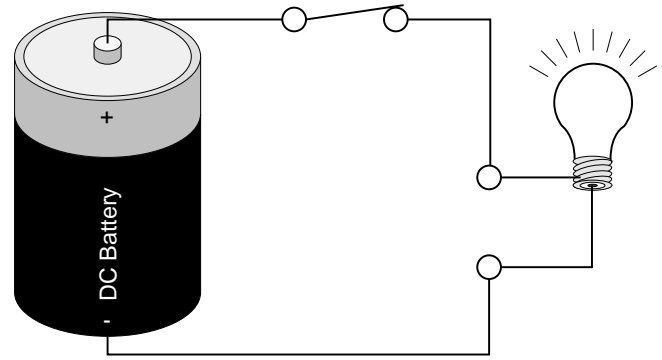

Figure 11. Simple Ungrounded Circuit

these posts needs to be connected to ground to make a circuit work. Consider the very simple example using a 1.5V battery, a switch, a light, and insulated wire connecting the set together as shown in Figure 11. It could be mounted on a piece of wood and no one would take a second glance because it represents the most basic tenants of electrical theory. When the switch is closed, electrons flow out of the negative post, through the bulb to light it, and return to the positive battery post. When the switch is open, there is no path for the electrons and the light remains off. Notice that nowhere in the simple sketch do you see the schematic symbol for ground.

If you were to take a voltage measurement, it would be possible to use any point in the circuit as a reference, and measure any other point with respect to that reference. A reference point does not need to be electrically connected to “ground.” In this ungrounded circuit any measurement made in this circuit with respect to Earth ground would mean very little since there is no connection anywhere in the circuit to ground. Now, if you were to connect the positive post to Earth ground, and measure the negative side, you would see the battery’s potential with a negative polarity. If you were to instead connect the negative post to ground and measure from ground to the positive side, you would see the same amount of voltage, but with a positive polarity.

The term “grounded bridge” infers that some part of the amplifier is connected to ground. Well, yes, but not the power supply. Refer to Figure 12. The reference for the power supply is controlled by a portion of the output stage. This will be explained later.

As explained in the paragraphs above, a basic DC battery supplies a certain voltage at the positive terminal with respect to the negative terminal, regardless which post (if any) is connected to ground. If it is a 1.5V “D Cell,” the battery will produce 1.5V at one post with respect to the other post. If the ground reference were movable, the 1.5 VDC battery could deliver +1.5 VDC and –1.5 VDC in

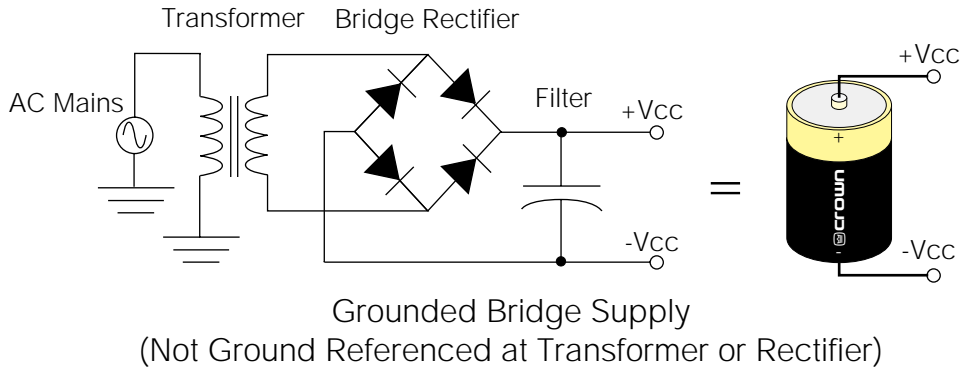

Figure 12. Ungrounded Power Supply for the Grounded Bridge

One part is positive, the other negative. The second two quadrants, called the “Low Side,” operate very differently. Figure 13 shows the basic grounded bridge with the ungrounded supply.

Under static conditions all output devices are held in an off condition. This balances the output stage bridge and keeps the $\pm V_{cc}$'s equal with respect to ground. Since the

alternating periods. The net effect is a voltage swing with a total range of 3V from maximum positive to maximum negative.

Shifting the ground reference may not be very practical for the simple light bulb circuit in Figure 11, but this is exactly how the grounded bridge topology works in Crown amplifiers.

Refer to Figure 12. There are several major differences between this supply and supplies in Figure 8. First, notice that the transformer secondary is not center-tapped, nor is either side of the bridge rectifier connected to ground. This allows the supply to “float” with respect to ground. Second, notice that both $+V_{cc}$ and $-V_{cc}$ are generated from a single bridge rectifier. This means that only one filter capacitor is needed. Compared to the class “H” supply in Figure 8, this is a 75% reduction in parts required to build the supply. Since there is only one secondary, maximum efficiency is maintained in energy transfer from primary to secondary. Also, all parts of the supply are working at all times. This means full utilization (in other words, there is no waste). Comparing supply to supply, the grounded bridge supply is far superior.

Grounded Bridge Output Topology
As for the output stage, the grounded bridge is actually composed of a total of four quadrants. The first two, called the “High Side,” operate much like a conventional AB+B design. They drive the load directly via the amplifier’s hot (+) output.

supply has a total voltage of 80V and the Low Side is maintaining a ground reference balance, the positive and negative power supplies will measure $+40\text{ VDC}$ and -40 VDC respectively, with respect to chassis ground.

When the input signal goes positive (refer to Figure 14), the High Side NPN transistor (Q1) turns on. As it conducts, the signal to the load becomes more positive. This positive voltage is sensed by an op-amp and inverted. The negative output of the inverter causes the Low Side PNP (Q4) to turn on. As Q4 conducts, the negative side of the power supply approaches ground potential. Since the potential from one side of the supply to the other is fixed at 80V, the positive supply voltage increases *with respect to ground*. The speaker load is also referenced

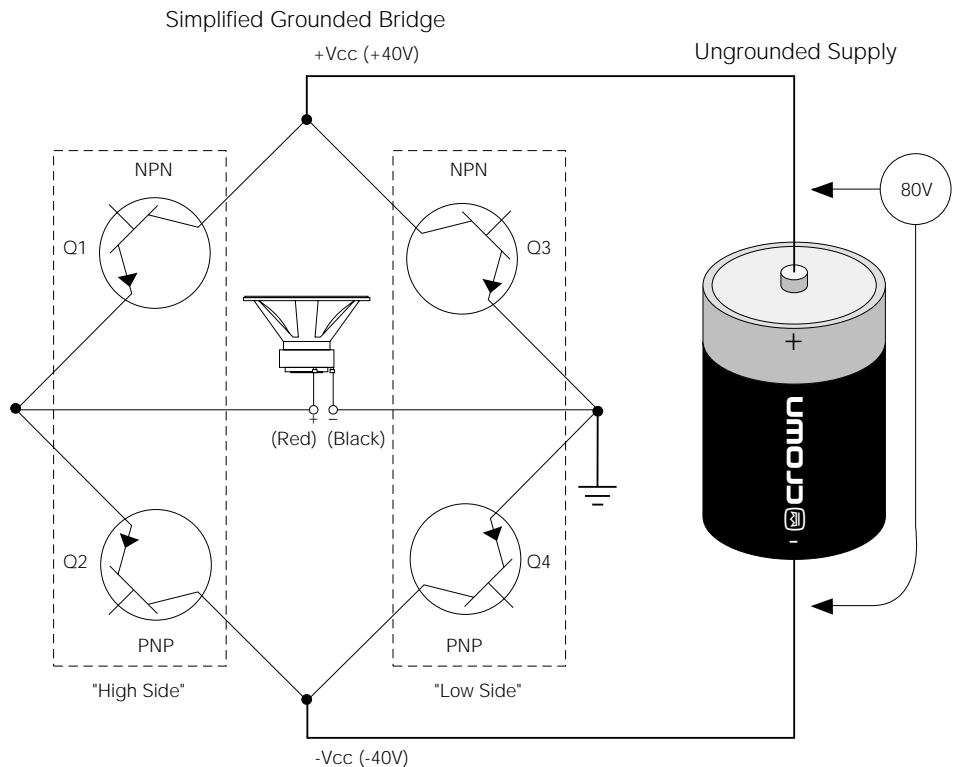

Figure 13. Grounded Bridge Under Static Conditions

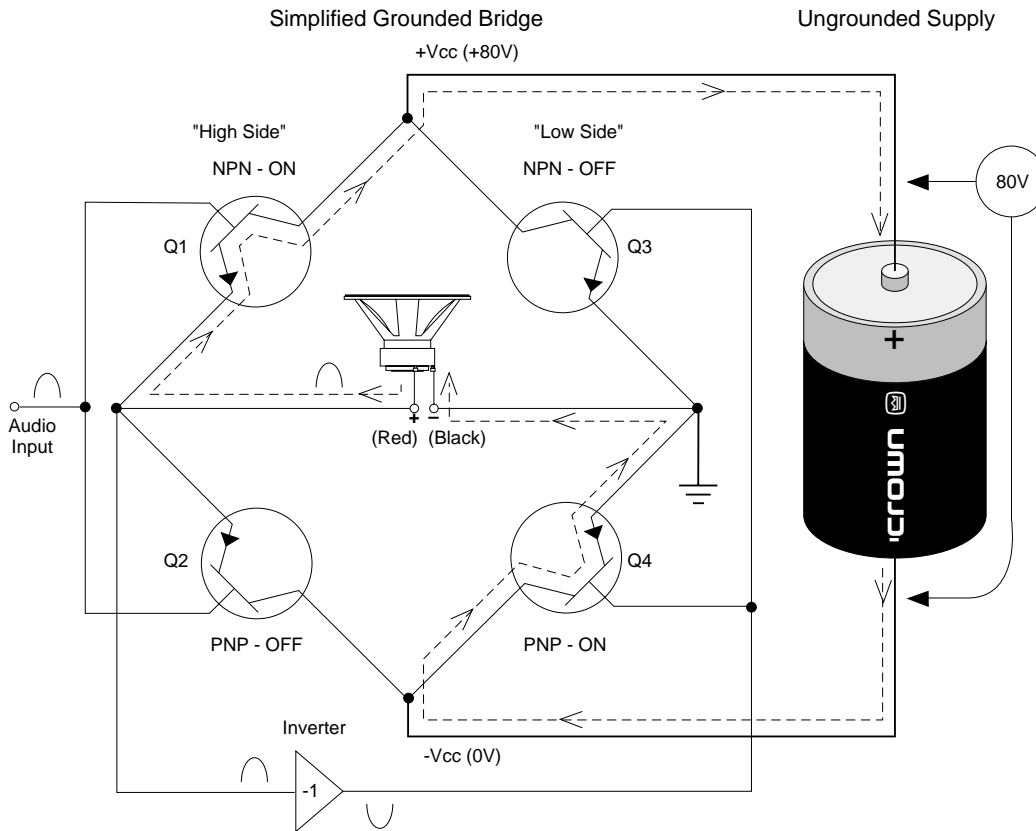

Figure 14. Grounded Bridge With a Positive Audio Input

to ground. At the peak of the positive input the Low Side PNP is at maximum conduction. This places $-V_{cc}$ at approximately 0V and $+V_{cc}$ at $+80V$ with respect to ground. With Q1 at maximum conduction, peak output reaches $+80V$ to the hot (+) side of the speaker.

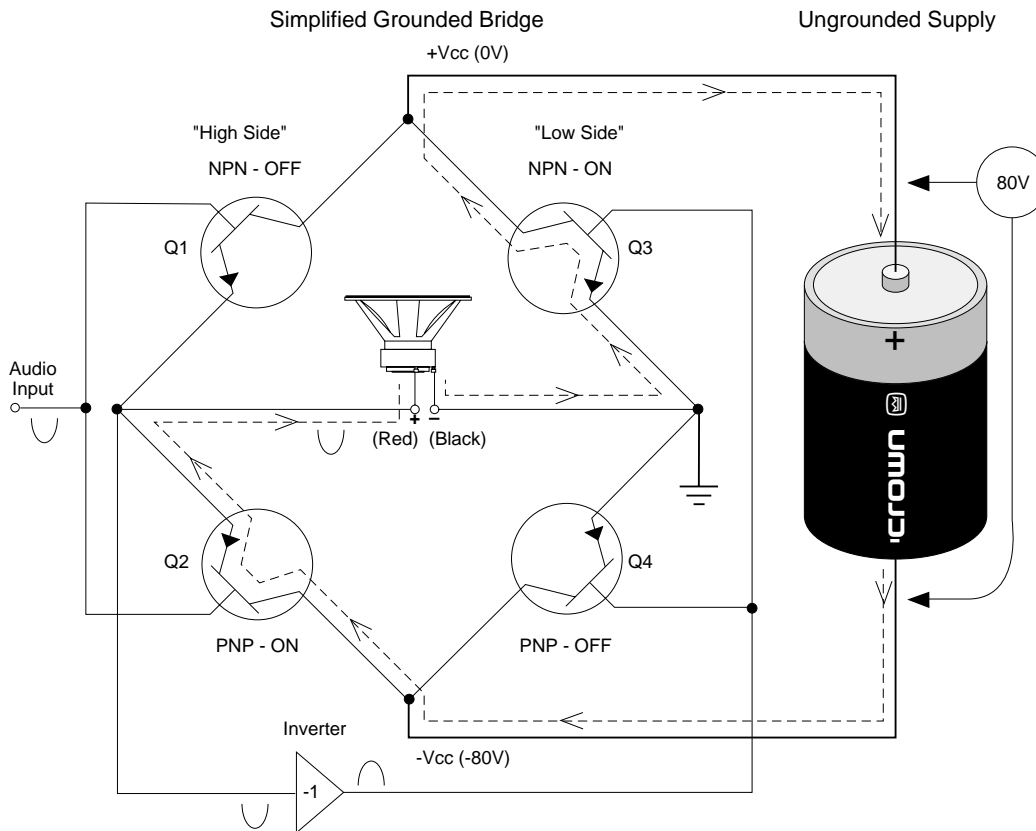

Figure 15. Grounded Bridge With a Negative Audio Input

Figure 15 demonstrates grounded bridge operation during a negative going audio input. The High Side PNP (Q2) conducts. The negative output is sensed by the load. The inverting op-amp supplies a positive voltage to Q3, the Low Side NPN, causing it to conduct. $+V_{cc}$ is drawn to ground potential and $-V_{cc}$ is forced to $-80V$. This allows the output signal to reach a maximum negative potential of $-80V$.

Over the course of the full input audio waveform, the speaker is allowed to see voltages ranging from $+80V$ to $-80V$ (160V peak-to-peak), all from a single 80V supply. Figure 16 shows the complete waveforms for your reference.

The magic of the grounded bridge is not really magic at all, just good common sense. Because the power supply is not ground referenced, it

is allowed to slide back and forth with respect to ground in a controlled manner. The Low Side of bridge performs this function in a clean and efficient manner. As was stated before, the grounded bridge works exactly like our light bulb example with the moving ground.

US VS. THEM

Although some esoteric amplifier manufacturers use class "A" topologies, they are very inefficient, generating a great deal of heat and providing very little output by comparison. Class "A" amplifiers are very expensive and require massive heatsinks for cooling. Class AB+B is the best combination of basic biasing techniques for high efficiency and low distortion. Almost all audio manufacturers today use AB+B or some very close variation in their output stage designs. Even class "H" designs use AB+B biasing techniques.

Class "H" designs, although quite efficient, produce distortion anomalies unacceptable to Crown's high standards for sonic excellence. Also, even though the class "H" design is efficient, the flow of current and distribution of heat is unequal from lower to upper transistor banks. Class "H" designs require a four part power supply with separate rectifiers and filters for each part. Power transformers have four separate center-tapped secondaries. This means that energy transfer within the transformer is less than optimum, the cost of the transformers are quite high, no power supply section is ever fully utilized, and many more parts are required than in the grounded bridge amplifier. The power supply in a grounded bridge amplifier requires fewer parts, energy transfer is more efficient, and all parts are fully utilized all of the time.

In a class "H" amplifier the output signal must cut across the power supply voltages. In a grounded bridge amplifier the audio controls the power supply and no transis-

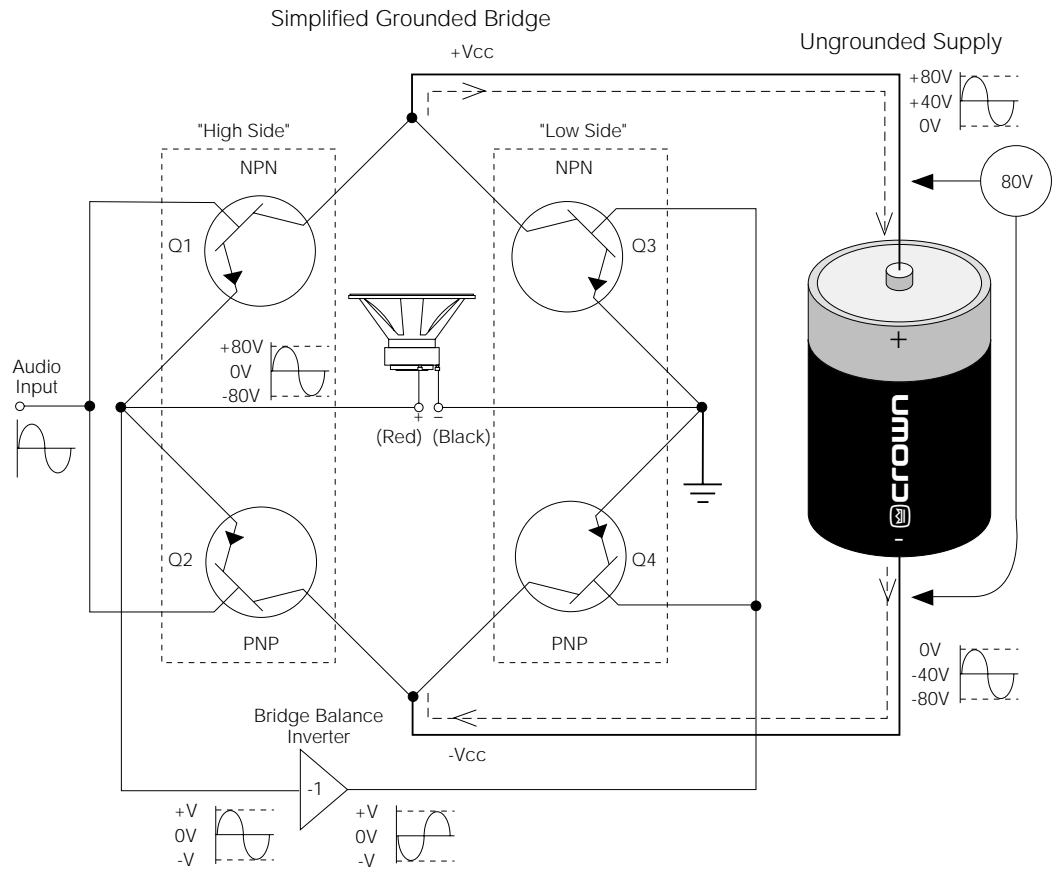

Figure 16. Grounded Bridge Summary

tors ever go into saturation before clip. With regard the maximum voltages a transistor is exposed to, no transistor in the grounded bridge ever sees more than half the peak-to-peak voltage delivered to the load. This is not possible in a conventional or even class "H" design.

The heat dissipated by the output transistors is evenly distributed not only between devices placed in parallel, but also between devices in the High and Low sides of bridge. This, along with other thermodynamically superior mechanical technologies used by Crown makes the grounded bridge highly reliable under all operating conditions.

Figure 9 made comparisons between single transistor operation and series transistor operation. The disadvantages of both were made very apparent. Refer to Figure 17 to compare series class "H" dissipation to grounded bridge dissipation. Although transistors still dissipate heat in the grounded bridge, the heat distribution is even and is lower overall at most operating levels. Also, both transistors are conducting evenly and neither are saturated. This results in clean undistorted power, not only at the zero crossing point, but all the way from the zero crossing to peak power. The efficiencies of the grounded

bridge power supply and output stage, along with other supporting technologies, make the grounded bridge the single best design for high power amplification available today.

HISTORICAL NOTE

The grounded bridge design was invented by one of Crown's senior engineers. In 1974 the first grounded bridge amplifier was introduced: the M-600. It was primarily used by Crown in industrial power supply applications. It was tried and proven in the industrial market long before it was ever introduced to the less demanding applications of audio amplifiers. In 1984 Crown introduced the MT-1000. It was two rack spaces, put out as much as 500W/Ch, weighed less than 40 lbs, and was priced lower than any comparable product. Since then the grounded bridge has been used in over 20 new models introduced by Crown for virtually every major sector of the audio market.

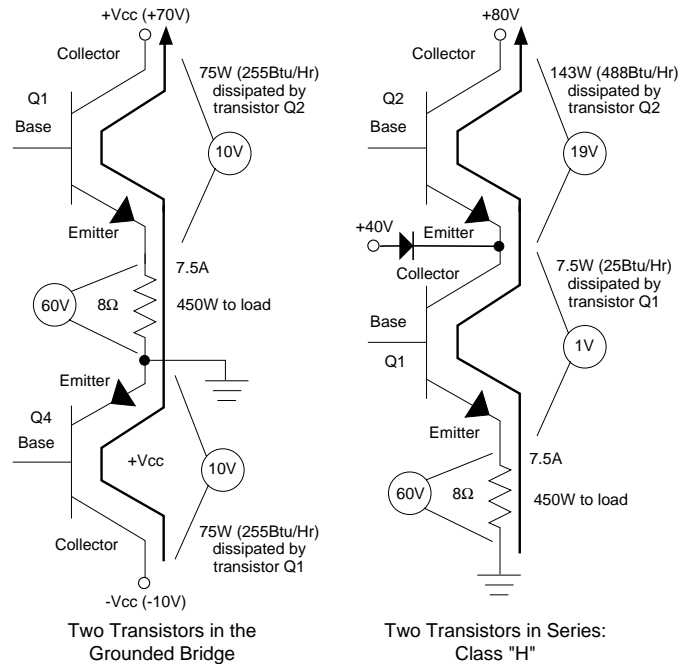

Figure 17. Heat Dissipation Comparison



Guaranteed Excellence

Crown International, Inc.
 PO Box 1000 Elkhart, IN 46515-1000
 Ph. 800-342-6939/219-294-8200
 Fax 219-294-8301

"Fast Facts" Automated Fax: 800-294-4094
<http://www.crownintl.com>

Trademark Notice:

DC-300® and Crown® are a registered trademarks of Crown International Inc.