

NOTE!: METAL TABS ON "T" PACKAGE CONNECTED TO -V

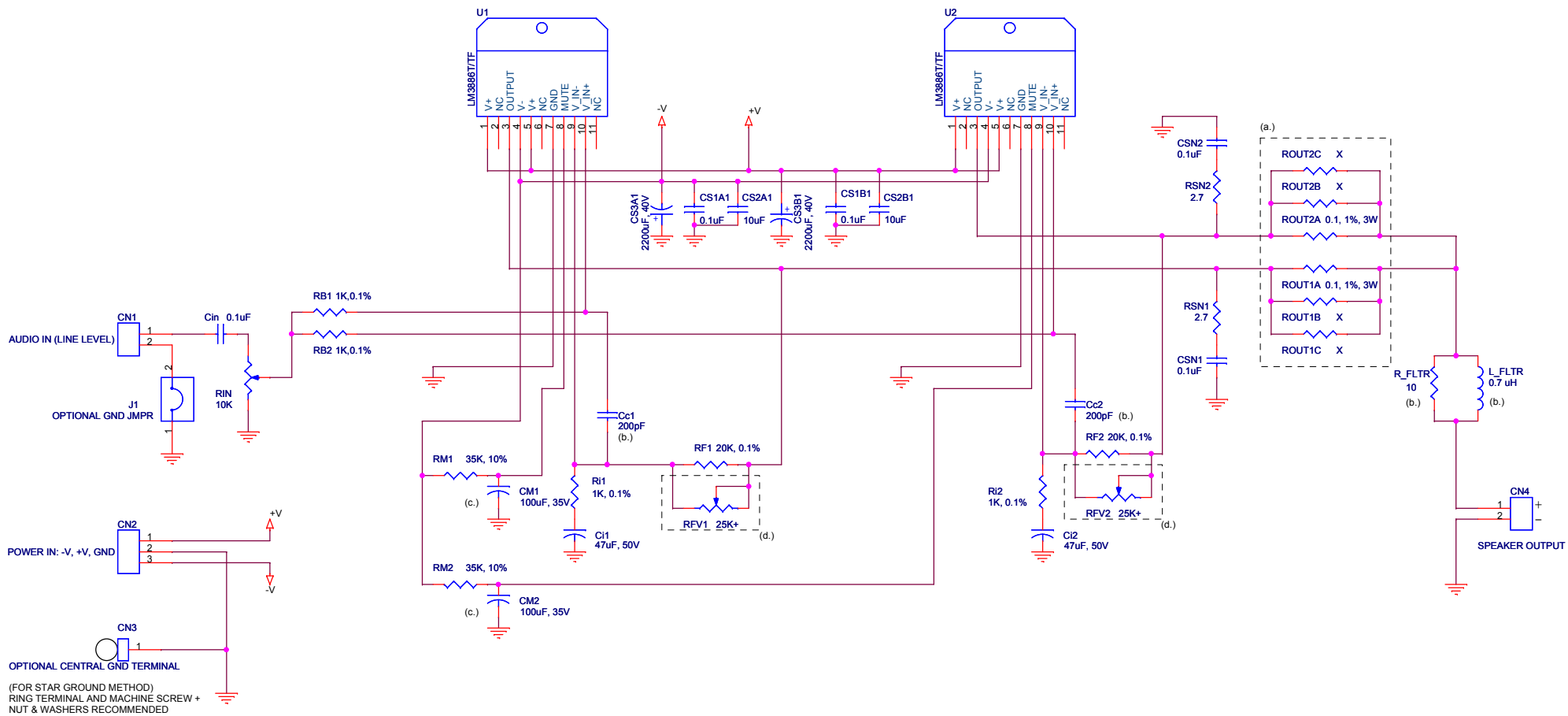

NOTES:

- a. ADDITIONAL RESISTORS MAY BE USED IN PARALLEL AS NEEDED TO REACH INTENDED VALUE
- b. OPTIONAL COMPONENTS
- c. CAPACITOR VALUE MAY BE INCREASED FOR GREATER MUTE FUNCTION TIME
- d. OPTIONAL GAIN ADJUSTMENT RESISTOR (REPLACES RF1, RF2 WHEN POPULATED)

ENGINEER: M. MCLEOD		
Title PA100 PARALLEL ONE CHANNEL AUDIO AMP 100W		
Size B	Document Number 01-PAX100-SCH	Rev A
Date: Saturday, September 29, 2007	Sheet 1	of 1