

The Pearl Phono Stage

(c) 2001, Wayne Colburn, Pass Laboratories

Introduction

Nelson Pass' Zen amplifiers have generated a tremendous amount of interest over the past seven years. At Pass Labs we enjoy a small daily flood of e-mail and telephone calls about them, and a substantial number of these are requests for a magnetic phono stage preamp design.

The philosophy of the Zen amplifiers is based on the premise that simpler audio circuits tend to sound better, and the design examples explore just how simple they can be. Ideally they comprise a single gain stage, perhaps a single gain device, and achieve good performance without the use of negative feedback. This makes for a clear, if not always achievable goal.

Pass says that it's much easier to design a line level or even a power amplifier with a simple single gain stage than it is a phono stage. There are three reasons for this: High gain, low noise, and dramatic frequency equalization.

At the lowest frequencies, the phono circuit must amplify the input voltage by roughly a thousand times. By contrast, a typical power amplifier amplifies by 20 to 30 times, and a typical line level preamplifier by maybe 10 times. A thousand times is a lot more, particularly if high quality is also required.

The input noise of the phono stage must be small in comparison to the output of the magnetic cartridge. Typical signal values are on the order of a thousandth of a volt (1 millivolt), and for acceptable performance we need the noise contributed by the circuit to be about a thousandth of that. This value is about a millionth of a volt (1 microvolt).

The equalization curve, known as the reverse RIAA equalization, boosts the bass frequencies by a factor approaching 10 times the reference gain at 1,000 Hz, and reduces the high frequencies by a factor of 1/10 of the reference. It must do this with about 1% accuracy over the entire audio band, and ideally with the same sonic signature.

All this and sound musical, too.

Previous Zen circuits, such as Bride of Zen, do not meet these requirements. First off, there was no way we would get 60 dB gain from a single gain device. Second, Mosfets are simply too noisy to be practical with microvolt input levels. Third, the equalization circuitry is only practical either as part of an active feedback loop or as a passive circuit in between gain stages. This leads us to a design which sandwiches a passive RIAA equalization network in between two simple Zen stages.

Simplified Circuit

Figure 1 shows a simplified version of such a circuit. At the input, Q8 is an N channel JFET operated in common source mode without feedback. The Drain of the JFET delivers current to the RIAA equalization network, developing amplified voltage which follows the reverse of the recording curve. The output of the equalization network drives the gate of Q6, which like the input stage operates common Source without feedback and drives a Drain resistor which develops the output voltage.

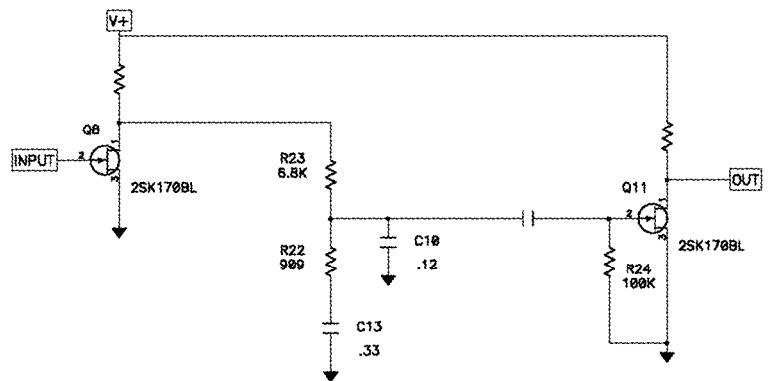

Fig.1

The gain devices chosen are very low noise JFETs which have a noise floor on the order of 1 nanovolt, much quieter than the MOSFETs used in previous Zen projects, and quiet enough to work with higher output moving coil cartridges.

Figure 2 shows a less simplified version of the circuit in which some additional features are included which extract greater performance from the two gain stages. First off, Q8 has been expanded into Q8 through Q11 operating in parallel. The input noise energy of these devices is inversely proportional to the number of devices in parallel, and so having four of them gives us a 6 dB improvement in signal to noise. Having four of these devices also allows us more gain from the stage, and more linearity by virtue of the higher current going through the set of devices.

We also see something new in Q5, a cascode transistor which shields Q8-Q11 from the voltage output while interposing itself very little on the character of the signal. Cascoding this stage further increases the available gain, improves the bandwidth, and lowers the distortion. A discussion of Cascode operation can be found in the article "Cascode Amp Design" which is available off the passlabs.com website.

Similar treatment is given to the second gain stage, where Q6 is seen to actually be a pair of JFETs in a single package and is cascoded by Q4.

Figure 3 shows the simplified circuitry for the power supply regulation for one channel only. The input to this circuit is about 40 volts DC unregulated, and the output is about 30 volts DC with as much noise

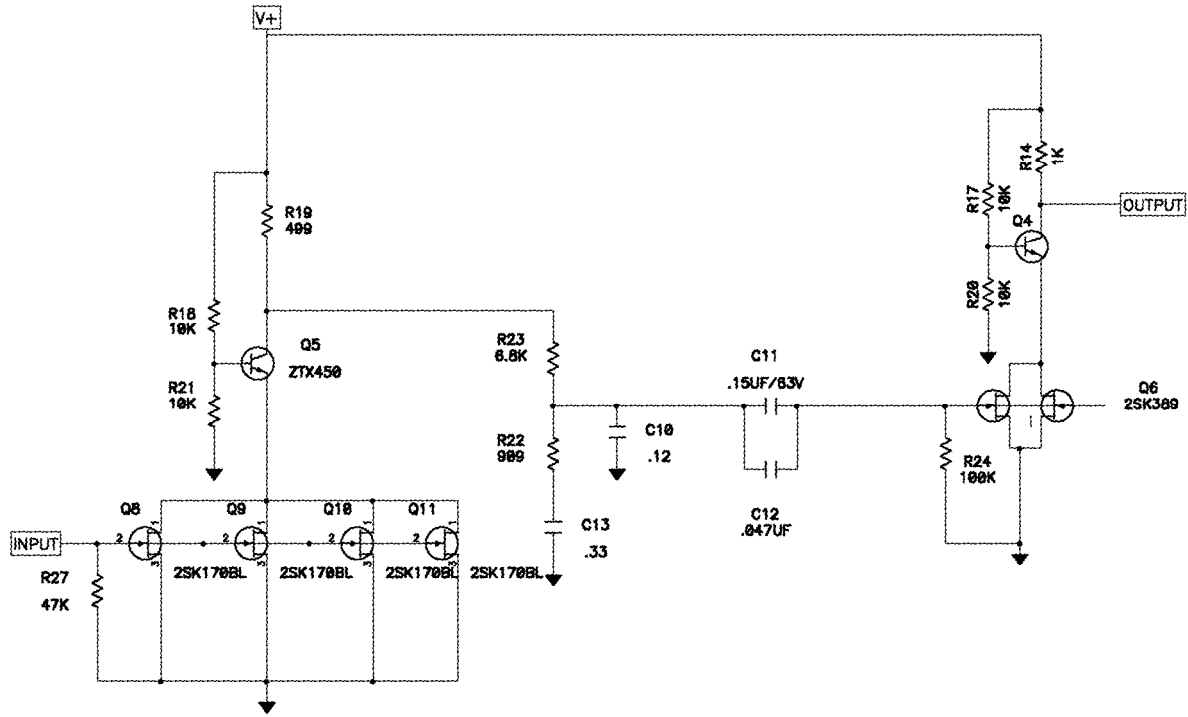

Fig.2

removed as possible. R2 and C1 form the first passive filter removing noise, and R3 and C2 form the second passive filter. D1 is used to form a 9.1 Volt DC reference which serves as the input to the discrete op amp formed by Q2, Q12, and Q1, whose output is seen at the Drain of Q1. This regulated voltage is passively filtered by R8 and C15, and goes to drive the V+ of the second gain stage.

The first gain stage needs a little more filtering, which is provided by capacitance multiplier Q3, which follows the filtered DC voltage across C7 and filtered again by C8.

Figure 4 shows a diagram of the unregulated power supply, whose components will not be found on the PC artwork in this article or in the parts list. It provides two isolated DC voltages at about 40 volts one for each channel, each powering a regulator from Figure 3.

Fig 4 is simply a suggestion using an Avel Lindberg 4007 transformer, Plitron 017017201, or their equivalents. It is not essential to use this unregulated supply. If you have another source of 40 Volts DC, feel free to try it. This circuit should be fused with about a 1 amp fast-blow fuse.

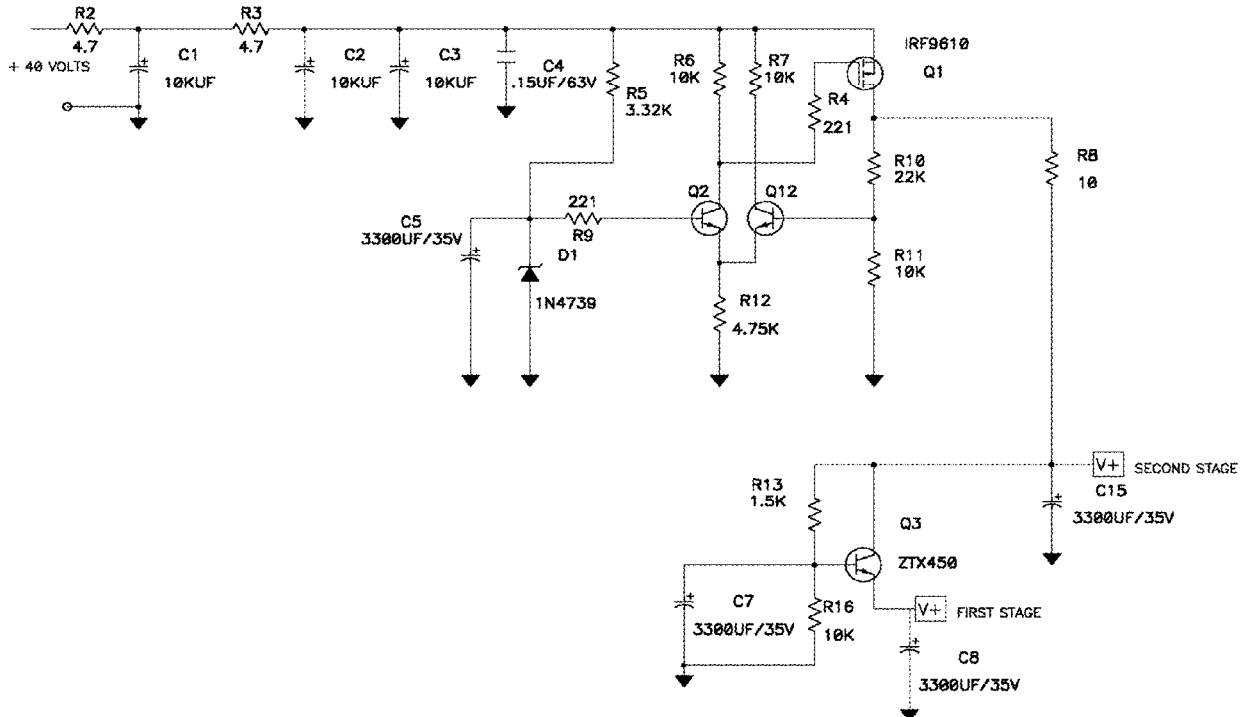

Fig.3

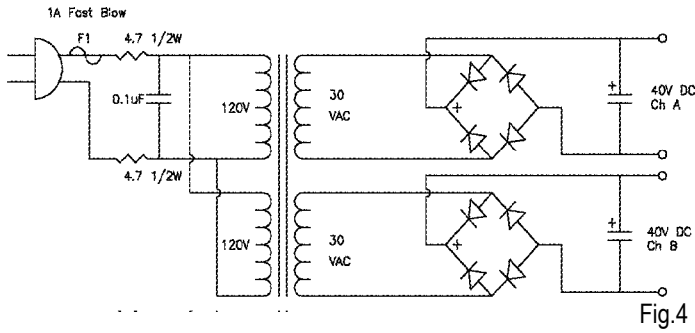

Fig.4

In this example, the AC line is filtered by two 4.7 ohm 1/2 watt resistors and by a 0.1 uF film capacitor rated at AC line voltages. A good example is Digikey part P4603-ND. This filter is not essential.

The twin 30 Volt AC secondary windings of the transformer are rectified by bridges rated at 2 amps and 100 volts or more such as Digikey 2KBP01M-ND. The DC is stored in 10,000 uF electrolytic capacitors. An example of this part is Digikey P6939-ND.

The unregulated supply is best kept at a distance, say a couple of feet, from the active gain circuitry to avoid noise pickup from the magnetic fields of the supply.

The Unsimplified Circuit:

Figure 5 shows the detailed schematic of all the components appearing on the PC board, and this discussion covers those parts.

In the first gain stage we see the addition of R28 - 31 which provide ballast to the JFETs, improving the matching, raising the input overload voltage, and lowering the distortion. R27 is the input load resistor, and is the maximum value recommended. The phono cartridge can be loaded with lower impedances simply by placing resistors and capacitors across R27.

Unloaded, the output gain is $4 * 499 / (45+22)$, 29 times and 29 dB. The 4 in the equation is from the four transistors, the 499 is the output resistance, the 22 comes from the 22 ohm resistors, and the 45 is the equivalent ohms from the transconductance of each FET.

The resistors and capacitors of the equalization circuit shape the response by both loading the first gain stage and dividing it. R19, R22, R23 and R24 along with C10, C13 and C11 + C12 form the correct response to about +/- .1 dB when used with 1% tolerance resistors and 2% capacitors.

The second gain stage uses a 2SK389-BL dual FET ballasted by R25 and cascoded by Q4. The gain of this stage is a flat 30 dB, and the output from Q4 goes out to the world through coupling capacitor C9.

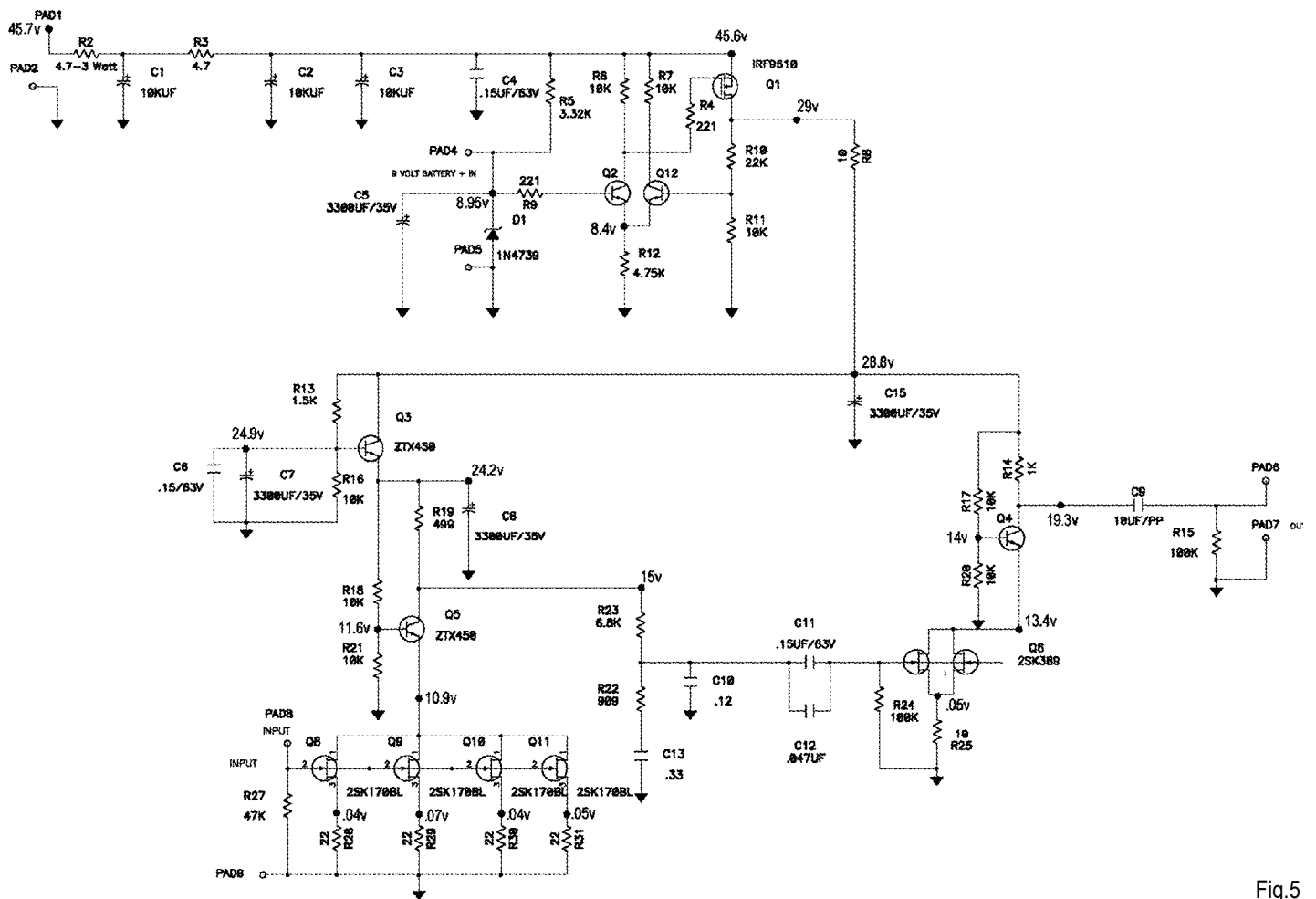

Fig.5

Construction:

All parts are available from Digikey and MCM electronics. Resistors are 1% 1/4 Watt. Capacitors are Panasonic for electrolytics and Panasonic Polypropylenes for the RIAA section.

The two isolated supplies will ultimately have their Grounds meet each other, and the best place to accomplish this is at the output. If this preamp is constructed with two channels in the chassis and an external supply, then the grounds should meet at the output connectors. These output connectors should be close together, and attach to chassis ground at this point.

Check your part numbers against the parts list. Be sure to do this while stuffing the board, also. The component placement on the board is shown in Fig 6 and is also silk screened on the PC board itself.

Stuff and solder the 1/4 watt resistors first. (Figure 7) Measure component lead spacing and bend resistors with a resistor bender, so the leads have sharp fitting angles. You can include stuffing the diode (D1) at this point, as it is almost the same size. Be sure to double check the diode direction. The cathode side is indicated on the PCB as well as the part.

Be sure that the resistors and diode are nice and flat on top, then bend the leads on the underside of the board outward at about a 45-degree angle. (Figure 8) If you bend them too far apart on the underside, it will inhibit the removal of the parts if necessary. Solder and clip, making

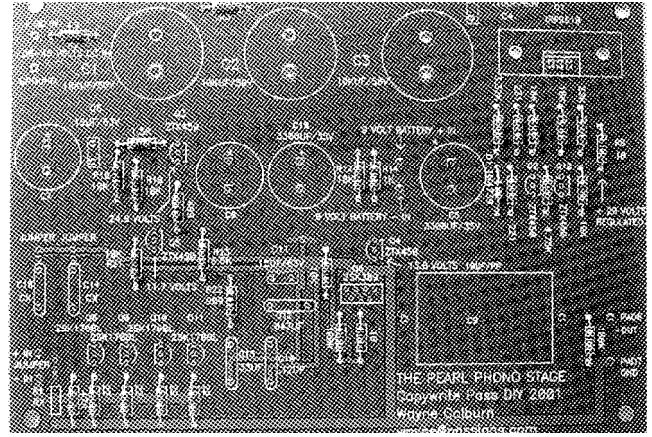

Fig.7

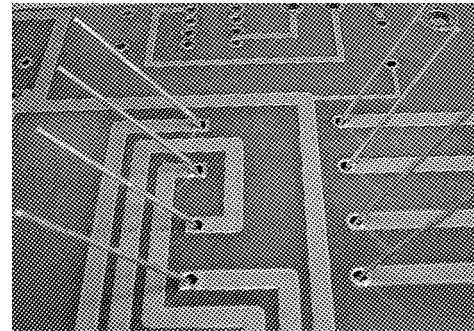

Fig.8

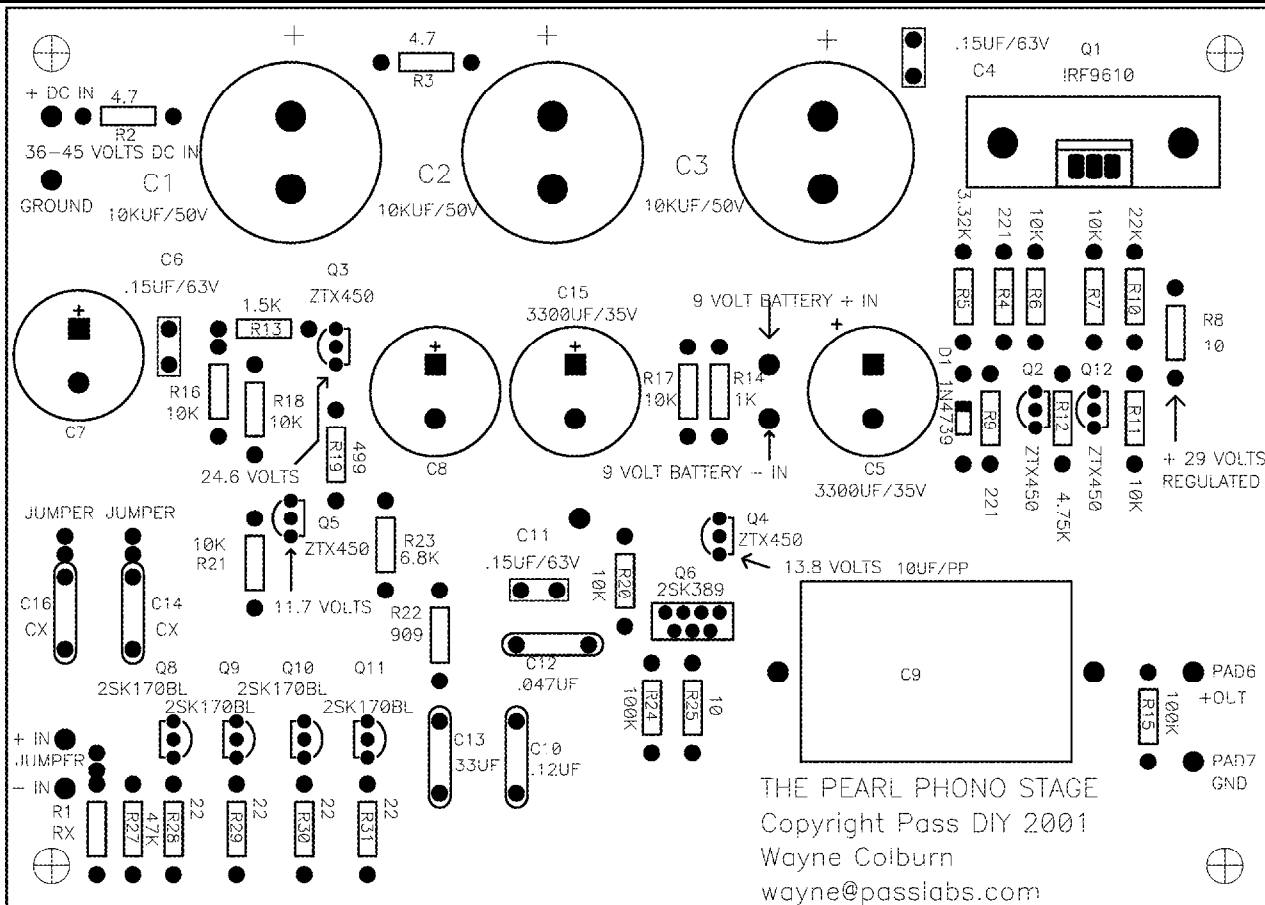

Fig.6

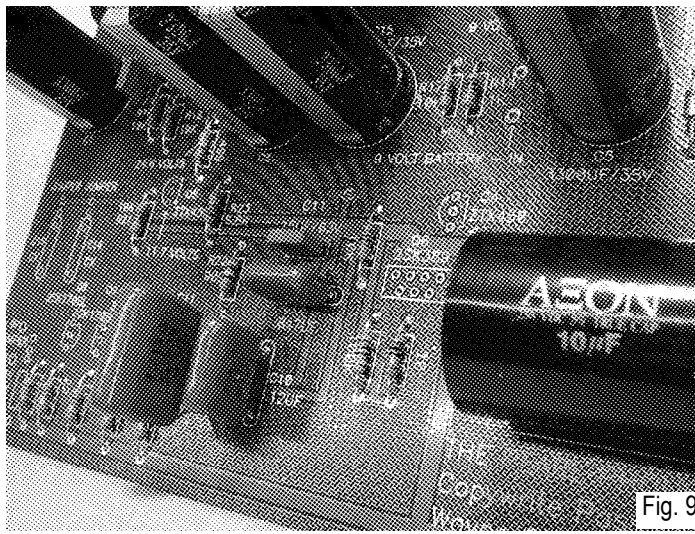

Fig. 9

sure all solder joints are of good electrical connection.

Place the capacitors in the board next. Capacitors can help protect the static sensitive transistors that you will add later. Some of the ceramic caps may need to be raised slightly, due to the size of the part versus the spacing of the lead holes. (Figure 9) Be careful to note the direction of the electrolytic caps. (Figure 10) The polarities are indicated on the PCBoard as well as the parts. Carefully solder in place and clip the leads.

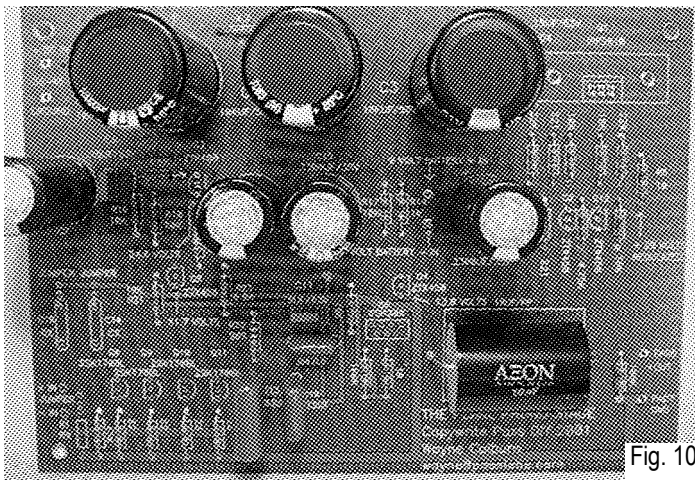

Fig. 10

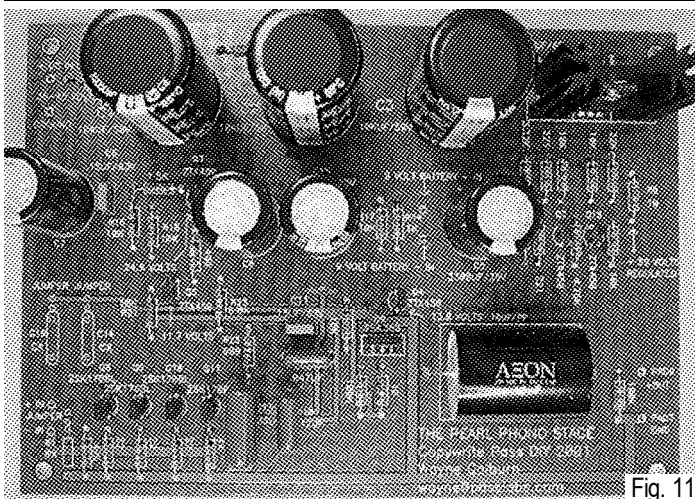

Fig. 11

Next, insert the transistors Q2 - Q12, standing them up neatly. (Figure 11) Don't forget these parts are static sensitive. They also need to be placed on the board in the proper direction. Just match the shape of the transistor package with the shape indicated on the PCBoard. Solder and clip.

Place the 9610 transistor on the board mount heat sink, using a 4/40 - 1/4" screw and kep nut. Tightening the transistor correctly will ensure proper heat distribution of this part. Use the plastic washers to isolate the heat sinks from the PCBoard. (Figure 12) Solder and clip the transistor and the heat sink to the board. It should now look like Figure 13. You are ready to test it!

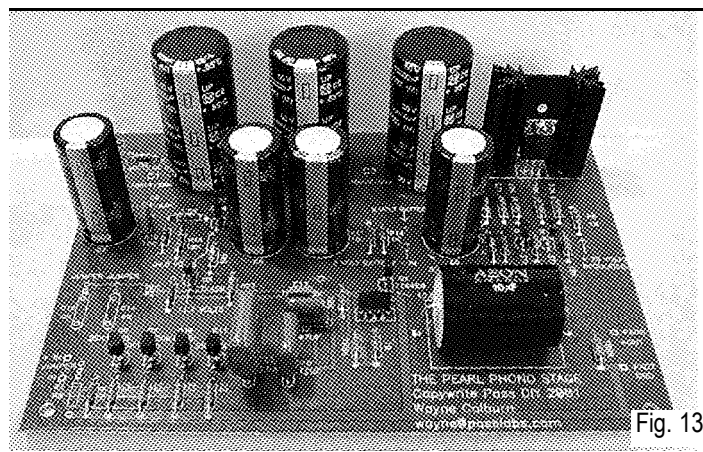

Fig. 13

Testing:

If you have access to a Variac™ and can bring up the voltage slowly, then do so, watching the current draw through R2 in the power supply of each channel. The circuit draws about 50 mA per channel, so you are looking for a voltage drop across R2 of about 0.25 volts.

If you don't have a method of bringing up the supplies slowly, you will have to plug it in and hope for the best. Observe the voltage across R2 as in the previous paragraph and keep an eye out for smoke.

Figure 5 details the DC voltages to be found at all points of interest in the circuit, and the PC board artwork labels many of these. You will need an inexpensive DC voltmeter to confirm these voltages to within a few percent accuracy, say 5% or so.

If the voltages are correct, then the chances of the preamp working are very good.

Objective Performance:

Figure 14 shows the gain of the phono stage referenced to the input voltage and reflecting the inverse RIAA equalization curve. Figure 15 shows a more refined version of this curve showing deviation from a perfect RIAA curve. We see that using the parts specified we get accuracy to within 0.15 dB over the audio band.

There is a slight bump up in the 30-40 Hz range of about .15 dB, which we don't find objectionable at all, particularly since the mid to high frequency character is exceptionally smooth.

Figure 16 shows Total Harmonic Distortion (THD) plus noise. For phono cartridges in the 300 uV to 1 mV range, the characteristic is about optimal and the distortion is an easy to listen to 2nd harmonic at a quite low level.

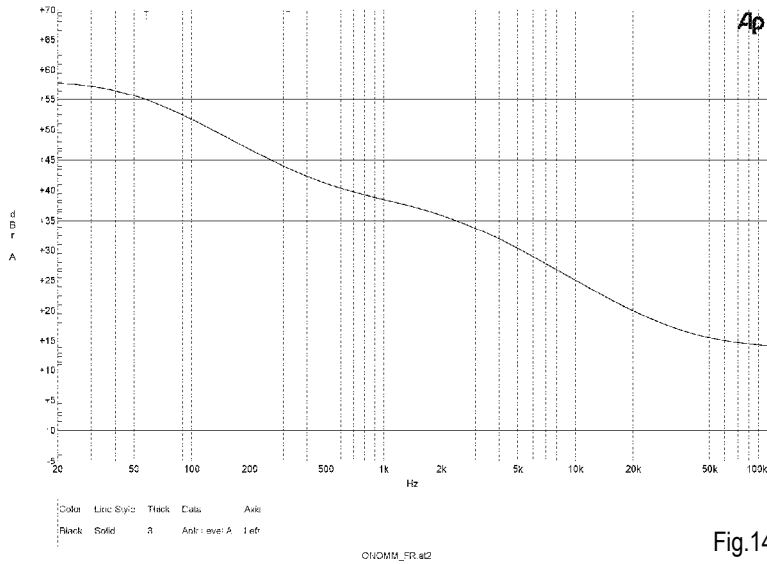

Subjective Performance:

The phono stage was tested on two different systems with a Grado Sonata (47 Kohms load), a Kiseki Lapus Lazuli (100 ohms load), and a Sumiko Celebration (1000 ohms load) cartridges all of which have outputs in the range of 400 to 500 microvolts.

The circuit was quiet and had sufficient gain. A subjective consensus has it that the phono stage offered precise imaging and spatial placement and good depth. Compared with the Xono, the Pass Labs reference, it was slightly noisier, and had less gain. From a sonic standpoint, it acquitted itself well in comparison, lacking only slightly in dynamics.

Conclusion:

Not bad for a simple circuit costing a couple hundred bucks. It acquits itself well against products costing several thousand dollars, and, in the tradition of the Zen amps, does so with single gain stages and an absolute minimum of components.

Biographical note: Fifteen years or so ago Pass placed an advertisement in the back of Audio Amateur which said:

Assistant Wanted. High Pay, No Work, All Glory

(Wayne is the guy who got the job.)

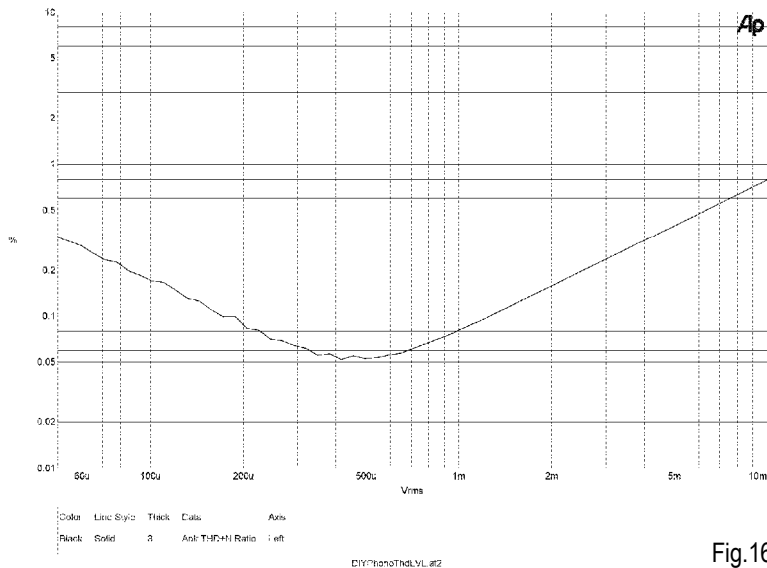
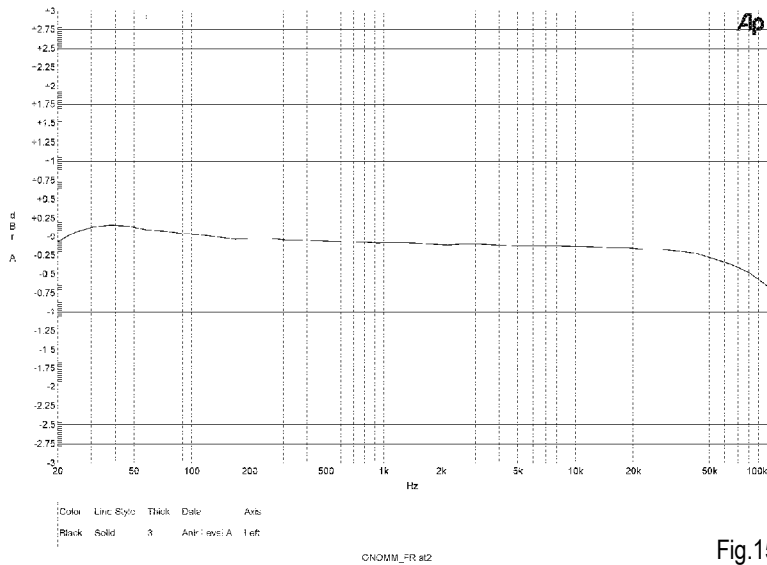

Soldering "Tips":

PCBoard Soldering can be a kind of art form, when done properly. The result should be a perfect physical and electrical connection, between the part lead and the solder pad on the board. I recommend that you find some solder with low lead content, and rosin core. This can help reduce the amount of lead being dumped into our landfills. You should also have a good soldering iron. Be sure the tip size is appropriate for the job. I suggest a 1/8" 3mm screwdriver tip.

Hold the iron tip on one side of the joint (where the part lead and solder pad should connect) and feed solder through the other side, on the solder pad surface. If the pad is hot enough, the solder will melt and flow like water around the whole surface of the joint. The cooled solder will have a "volcano" shape to it, appear shiny and the joint will have no voids or cracks. Success! (See figure 17)

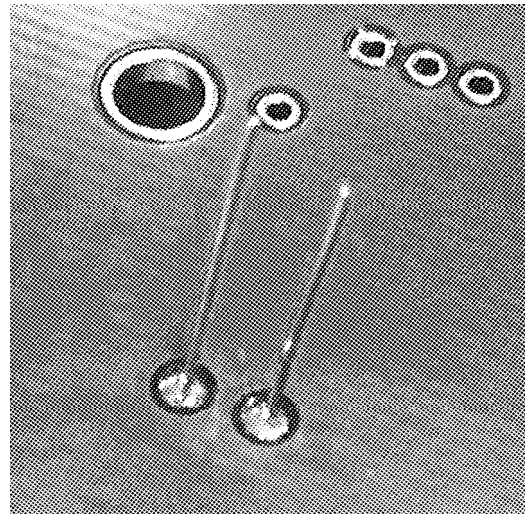

Fig.17

Bill of Materials

Qty	Ref Des	Value	DigiKey Part #	MOUSER PART #
3	C1,2,3	10KUF/50V	P6939-ND	
1	C10	.12UF	P3124-ND	
1	C12	.047UF	P3473-ND	
1	C13	.33UF	P3334-ND	
2	C14,16	USER VALUE		
3	C4,6,11	15UF/63V	P3154-ND	
4	C5,7,8,15	3300UF/35V	P5557-ND	
1	C9	10UF/PP		
1	D1	1N4739		
1	Q1	IRF9610	IRF9610-ND	
5	Q2,3,4,5,12	ZTX450	ZTX450-ND	
1	Q6	2SK389		
4	Q8,9,10,11	2SK170BL		
1	R1	User Value		
1	R10	22K		71-RN60D-F-22K
1	R12	4.75K		71-RN60D-F-4.74K
1	R13	1.5K		71-RN60D-F-1.5K
1	R14	1K		71-RN60D-F-1.0K
2	R15,24	100K		71-RN60D-F-100K
1	R19	499		71-RN60D-F-499
2	R2,3	4.7 2 WATT	P4.7W-3BK-ND	
1	R22	909		71-RN60D-F-909
1	R23	6.8K		71-RN60D-F-6.81K
1	R27	47K		71-RN60D-F-47.5K
4	R28,29,30,31	22		71-RN60D-F-22.1
2	R4,9	221		71-RN60D-F-221
1	R5	3.32K		
8	R6,7,11,16,17,18,20,21	10K		71-RN60D-F-10K
2	R8,25	10		71-RN60D-F-10
1		HEATSINK	345-1029-ND	