

2nd Order State variable filter independent gain and Q with notch output.

2nd Order State variable filter independent gain and Q with notch output.

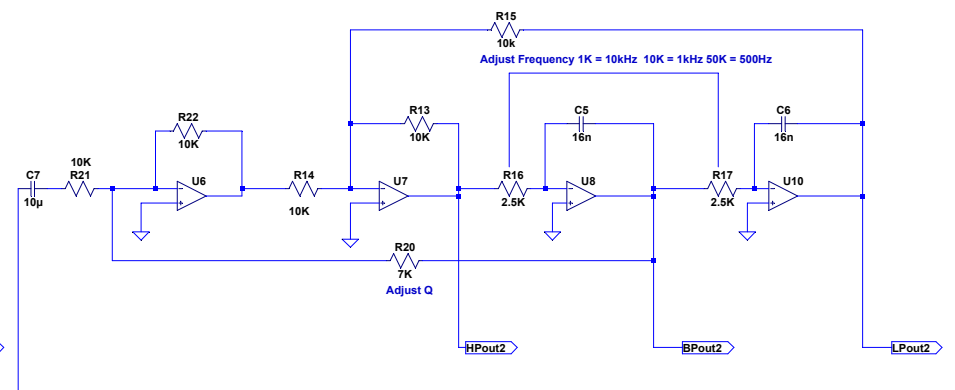
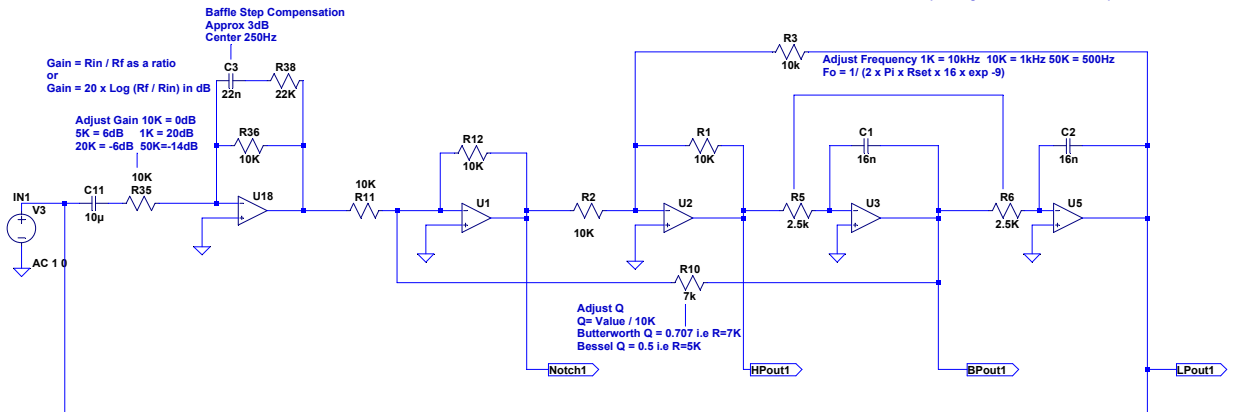

2nd Order State variable filter independent gain and Q with notch output.

2nd Order State variable filter independent gain and Q with notch output.

